



# CASE STUDIES

40 NEW  
CASE STUDIES



**OPW**   
a **DOVER** company

**FIBRELITE** 

**KPS**   
PETROL PIPE SYSTEM

SECOND EDITION

DEFINING | WHAT'S NEXT



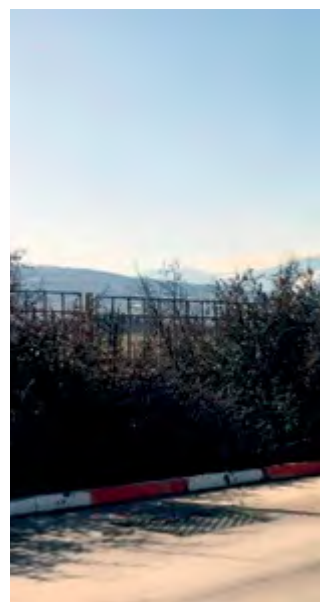



**OPW (a Dover company) is a global leader in fully integrated fluid handling, management, monitoring and control solutions for the safe and efficient handling of critical petroleum-derived fluids from the refinery to commercial and retail points of consumption.**

OPW provide loading systems, rail and transport tank truck equipment, tank gauging equipment and automated fuel management systems, valves and fittings, underground and above ground storage tank equipment, spill containers, overfill prevention devices, secondary containment sumps and flexible piping and fuel dispensing products.



**Fibrelite is a global leader in the manufacture and development of highly engineered GRP composite manhole covers, trench covers, steam covers and underground containment systems.**

Founded on core values of quality and innovation over 30 years ago, Fibrelite is proud to be at the forefront of composite technology, with creations including the world's first composite manhole cover! Recent developments include the first composite F900 load rated trench cover and first composite multiport system. Since 2013, Fibrelite has been a part of OPW (a Dover company) allowing us to offer an unprecedented portfolio of complementary best-in-class products. Fibrelite products are manufactured in the UK, US and Malaysia and supported by a global network of distributors.



**For over 25 years KPS has been leading the development of plastic petrol pipes in the forecourts around the world with safe, reliable and installation friendly products.**

Today the KPS Petrol Pipe System™ is sold and installed in Europe, the Middle East, Asia, China, South America and Africa. Our double wall piping is the most popular choice among installers and piping designers thanks to smart and compact solutions that make piping design and installation easier than ever! Since 2013, KPS has been a part of OPW (a Dover company) allowing us to offer an unprecedented portfolio of complementary best-in-class products.



**Dover is a diversified global manufacturer who deliver innovative equipment and components, specialty systems, consumable supplies, software and digital solutions, and support services.**

Dover combines global scale with operational agility to lead the markets we serve. Recognised for our entrepreneurial approach for over 60 years, our team of over 24,000 employees takes an ownership mindset, collaborating with customers to redefine what's possible. Dover is headquartered in Downers Grove, Illinois.





# RETAIL FUELLING - OPW - KPS - FIBRELITE

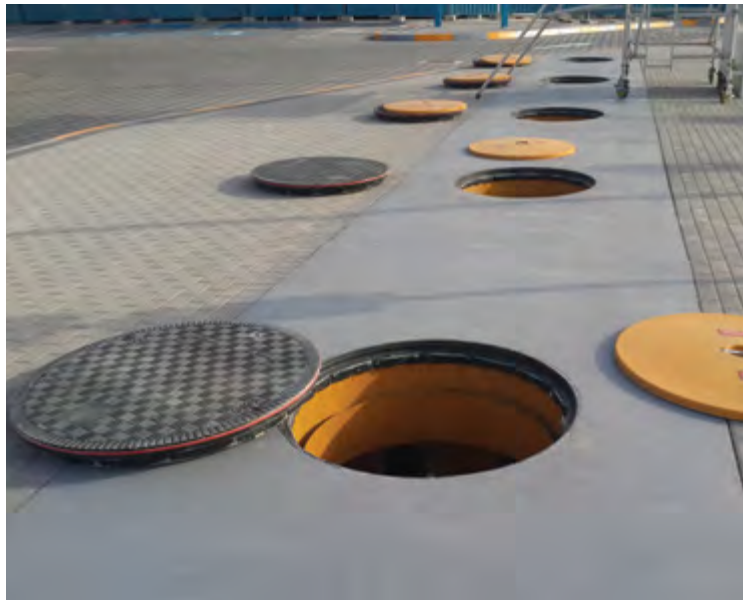



## OPW: Defining What's Next in Retail Fuelling

### An Unprecedented Range of Complimentary Best in Class Products

OPW is revolutionising fuelling operations worldwide by delivering the most innovative, fully integrated fuel transfer system, secondary containment, spill containment, overfill prevention and dispensing solutions in the industry, all designed to help retail fuel marketers provide consumers with the most efficient and safe fuelling environment possible. OPW offers solutions for conventional, vapour recovery, DEF, Ethanol, Biodiesel, CNG, LPG and Hydrogen fuelling, as well as a complete portfolio of solutions for above ground storage tanks.

### KPS Piping: The Simple Solution

- Available in conductive and non-conductive
- Engineered for installers: reducing cost and build time. In fact, KPS double wall fittings are the only system to weld both pipe walls simultaneously
- Sizes to fit every filling station requirement. Remote fill, pressure and suction, ventilation, vapour recovery or conduits



### Retail Fuelling Products

- Underground storage tank equipment
- Piping systems
- Covers and containment systems
- Dispensing equipment
- LPG equipment
- CNG equipment

### Fibrelite GRP Composite Covers and Underground Enclosures

- The global industry standard
- An unrivalled range of stock and bespoke colours, sizes and specifications to fulfil the demands of every project
- Manufactured and tested to deliver a lifetime of trouble-free service

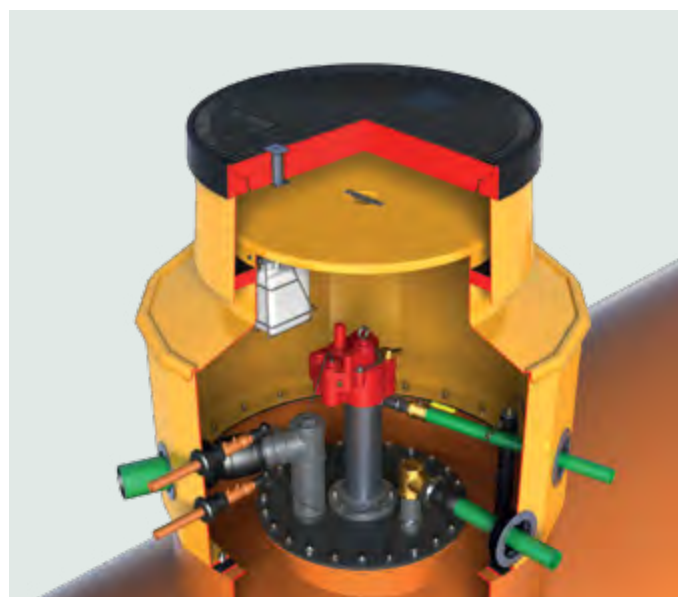



# WHY CHOOSE FIBRELITE - OUT WITH THE OLD

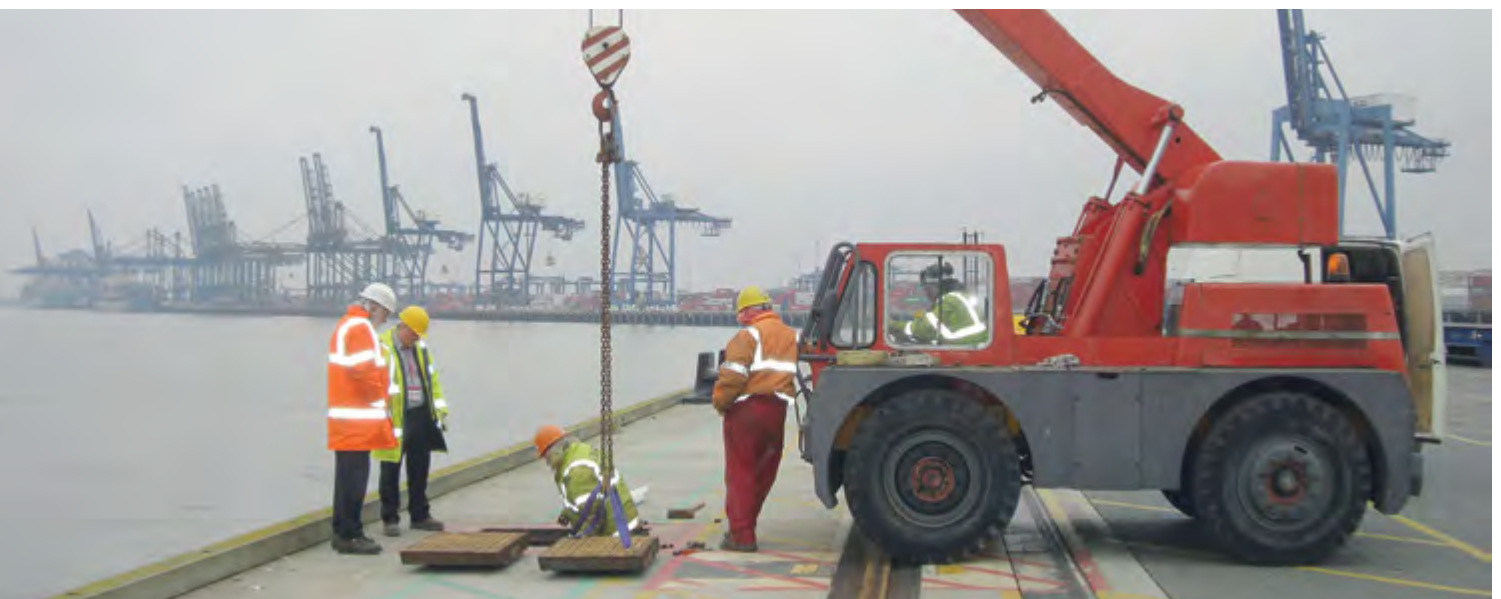



## Fibrelite Trench and Manhole Cover Benefits at a Glance

### Load Ratings from 1.5 to 90 Tonnes

- Load ratings from 1.5 tonnes (A15) to 90 tonnes (F900) BS EN 124
- Bespoke sizes and configurations available
- The widest range of GRP trench covers available to suit every requirement
- Perfect for access to drains, ducts and piping
- Trouble-free lightweight durable monolithic structure which will not delaminate
- Corrosion-resistant: unaffected by water, underground gasses and most chemicals
- Excellent insulator against heat
- Non-metallic, non-conductive and will not spark
- Can be installed onto our specialised frame or an existing rebate

- Treads incorporate an anti-slip material equivalent to modern high-grade road surface
- Safe easy-lift manual removal using Fibrelite's ergonomic lifting handle, eliminating the risk of back injury or crushed fingers
- Locks available
- Available in virtually any UV stable colour, which will not flake, fade or crack
- Logos or custom markings can be moulded into the upper surface
- Covers can be custom moulded to accommodate pipework entry, shallow depths with stepped cover profiles, steam and gas release vents, inspection ports and much more

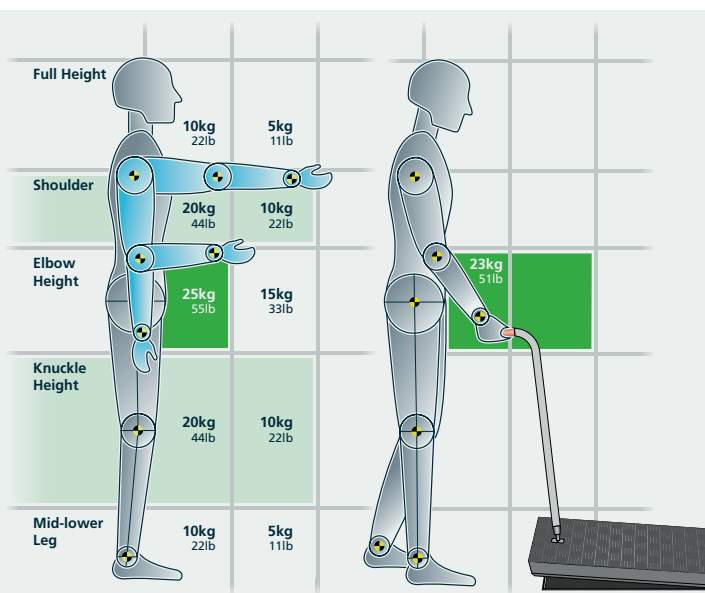



## Load Ratings up to 90 Tonnes

	<p><b>Up to: 90 Tonnes</b> <b>Extreme Heavy Duty (F900)</b></p> <p>For use in areas where extremely high wheel loads are imposed such as docks or airport runways</p>	
	<p><b>Up to: 60 Tonnes</b> <b>Super Heavy Duty (E600)</b></p> <p>For use in areas where high wheel loads are imposed such as loading areas</p>	
	<p><b>Up to: 40 Tonnes</b> <b>Heavy Duty (HS25/D400)</b></p> <p>For use in areas with frequent bus or heavy truck traffic, including carriageways and hard shoulders</p>	
	<p><b>Up to: 25 Tonnes</b> <b>Standard Duty (C250)</b></p> <p>For use in car parking lots, gas stations, industrial sites and areas with slow moving traffic</p>	
	<p><b>Up to: 18 Tonnes</b> <b>Standard Duty US (HS20)</b></p> <p>For use in traffic service areas as per AASHTO standard</p>	
	<p><b>Up to: 12.5 Tonnes</b> <b>Light Duty (B125)</b></p> <p>For use in car parks and pedestrian areas where occasional vehicular access is likely</p>	
	<p><b>Up to: 5 Tonnes</b> <b>Medium Light Duty</b></p> <p>For use in raised curb locations where light vehicular access is possible</p>	
	<p><b>Up to: 1.5 Tonnes</b> <b>Super Light Duty (A15)</b></p> <p>For use in areas where only pedestrians have access</p>	

## Ultra-Customisable

- Bespoke sizes and configurations: stepped, steam and gas release vents, inspection ports and many more
- Colours to stand out or blend in
- Logos and symbols
- Locks
- Many more options are available, just ask

## Perfect for Precast

Fibrelite can provide a GRP covering solution for almost any precast concrete trench, duct or channel layout using a unique adjustable tooling arrangement.

*“Combining high-performance, lightweight Fibrelite lids with our low-cost precast trench bases delivers a very high-value solution for our customers.*

*They get unparalleled strength and durability at a lower cost than has ever been seen in the market.”*

**George Schurr**  
President/COO, Trenwa Inc.





# TABLE OF CONTENTS

## 1. PORTS & AIRPORTS

- Felixstowe Shipping Port, UK 14
- Major Northern Airport, UK 16
- Container Terminal DCT Gdansk, Poland 18
- Port of Immingham, UK 20
- Manchester Airport, UK 21

## 2. PETROL STATIONS & FORECOURTS – OPW

- Major Oil Company, Belgium 24
- ENI, Germany 25
- Major Oil Company, Spain 26
- Petro Systems Management, Ireland 29
- LUKOIL, Bulgaria 30
- Fuel Retailer, Romania 32
- BP, UK 34
- BP, Portugal 36

## 3. PETROL STATIONS & FORECOURTS – KPS

- Wholesaler Petrol Station, Manchester, UK 38
- Tatneft, Russia 40
- VSE DLA AZS, Russia 42
- Sinooil, Kazakhstan 43

## 4. PETROL STATIONS & FORECOURTS – FIBRELITE

- Tora Petrol, Istanbul, Turkey 46
- LUKOIL, SisCo-M, Bulgaria 48
- Shell, North Hampshire, UK 50
- BP, Family Farm, UK 52
- Oil Company, Singapore 53
- Oil Company, Qatar 54
- Oil Company, UAE 56
- BP, Auckland, New Zealand 58
- Shell Oil Company, Guangdong Province, China 59
- Gazprom, Romania 60
- Oil Companies, Finland and Norway 62
- Petrol Forecourt and Green Area, Thailand 63
- Total Petrol Station, Cape Town, South Africa 64
- Premier Retail Fuelling Facility, USA 66
- Caltex Petrol Station, Cape Town, South Africa 67
- Convenience Store, Pennsylvania, USA 68
- WAWA Convenience Retailer, Pennsylvania, USA 69
- Z Energy Oil Company, Auckland, New Zealand 70
- Convenience Retailer, Tokyo, Japan 71
- Oil Company, Malaysia 72
- Oil Company, Tokyo, Japan 74

## 5. COMMERCIAL FUELLING

- District Heating, Rennes, France 76
- Fuel Delivery System, Maldives 78
- Thermal Power Plant, Saint-Pierre, Réunion Island 80

## 6. COVERS FOR PRECAST CONCRETE TRENCHES

• Utility Provider, USA	82
• Renewable Energy Power Station, UK	84
• Substation Rebuild, USA	87
• London Zoo, UK	88
• Biopharmaceutical Plant, Cumbria, UK - Phase 1	89
• Biopharmaceutical Plant, Cumbria, UK - Phase 2	90

## 7. POWER STATIONS & SUBSTATIONS

• Power Station, Doncaster, UK	94
• Renewable Energy Power Station, UK	96
• High-Profile Substation Rebuild, USA	99
• Cadent Gas, UK	100
• Utility Provider, USA	102
• Electrical Substation, Sheffield, UK	104
• Cadent Gas, D'Urton Lane, UK	106
• Lindley Oil Refinery, North Killingholme, UK	108
• Cadent Gas, Warrington, UK	110
• Substation, Cowpen Bewley, UK	112
• Substation, Chickerwell, UK	113
• Eggborough Power Station, UK - Phase 1	114
• Eggborough Power Station, UK - Phase 2	116
• Substation, Germany	117
• Natural Gas Substation, UK	118
• Substation, Drax, UK	120
• Energy Company, British Columbia, Canada	121
• Gas Valve Plant, UK	122
• Substation, Dorset, UK	124
• Substation, Elstree, UK	126

## 8. MANUFACTURING FACILITIES & DATA CENTRES

• Engine Manufacturing Facility, UK	130
• Cloud Computing Facility, Hong Kong	132
• Biopharmaceutical Plant, Cumbria, UK - Phase 1	133
• Biopharmaceutical Plant, Cumbria, UK - Phase 2	134
• Pharmaceutical Facility, County Durham, UK	136
• Pharmaceutical Facility, Northumberland, UK	138
• Royal Canadian Mint	140
• Engine Manufacturing Facility, UK	142
• Aerospace Facility, UK	144
• Paper Factory, Germany	146



## 9. STADIUMS & LEISURE

- La Liga Stadium, Central Spain 148
- Theatre, Amsterdam, Netherlands 150
- Leading Premier League Stadium, UK - Phase 1 151
- Leading Premier League Stadium, UK - Phase 2 152
- Football Stadium, London 154
- Leisure Centre, Sydney, Australia 156
- Vineyard, Jersey 158
- Leisure Centre, Keighley, UK 159
- Theatre, London, UK 160
- London Zoo, UK 162

## 10. FOOD PROCESSING

- Educational Facility, UK 164

## 11. RAIL TRAMS & UNDERGROUND

- Rail Maintenance Facility, Doncaster, UK 166
- Darlington Train Station, UK 168
- Oldham Tram Station, Manchester, UK 169
- Railway Maintenance Depot, London, UK 170
- Newcastle Train Station, UK 172
- Nottingham Tramline, UK 173
- Rail Project, Warwickshire, UK 174

## 12. ROAD & ROADSIDE

- Access Pits, Kuala Lumpur, Malaysia 176
- Hammersmith Flyover Bearing Pits, London, UK 178
- M4 East Bound, Newport, UK 180
- Turnpike Authority, USA 182
- Center of Disease Control, Atlanta, USA 183
- Tunnel Project, Germany 184

## 13. WATER & WATER TREATMENT

- Water Supplier, UK 186
- Water Company, Connecticut, USA 188
- Sewage Treatment Works, UK - Phase 1 190
- Sewage Treatment Works, UK - Phase 2 191
- Flood Alleviation Scheme, UK 192
- Waste Water Chambers, Derbyshire, UK 194
- Covers for Remediation Wells, UK 196
- Sewage Treatment Plant, UK 197
- Waste Water Plant, Antarctica 198
- Riverside Valve Chamber, Lake District, UK 200
- Culvert Access Solution, UK 201
- Severn Trent Water, UK 202
- Natural Spring, UK 204
- Water Monitoring System, Cádiz, Spain 206
- Pumping Station, Netherlands 208
- Water Treatment Facility, Florida, USA 210



## 14. PUBLIC AREAS

- RJ Utilities Ltd, Wrenthorpe, UK 212
- Hammersmith Flyover Bearing Pits, London, UK 214
- Duke University, North Carolina, USA 216
- Fire Water Tanks, California, USA 217
- Financial Centre, Singapore 218
- Electric Provider, Edmonton, Canada 219
- Hospital, UK 220
- Berjaya Times Square, Malaysia 222

## 15. STEAM VAULTS

- Indiana University, USA 226
- District Energy Provider, Boston, USA 228
- District Energy Provider, Minneapolis, USA 229
- University of Florida, USA 230
- Public Liberal Arts University, Willimantic, USA 232
- Leading University, Cambridge, USA 233
- Leading Engineering University, Boston, USA 234
- Leading North-Eastern University, Boston, USA 235
- District Energy Provider, Boston, USA 236

## 16. SHOPPING CENTRES & RETAIL PARKS

- Trinity Shopping Centre, Leeds, UK 238
- Leeds Market, UK 240

*Don't just take our word for it...*

*"Dakin Contractors have worked with Fibrelite for over 20 years now and we are happy to recommend Fibrelite to any company looking to utilise their services. We have always found Fibrelite to be the leader in their market... a company driven by providing a product and a service that their customers desire*

*and are constantly striving to improve their product in response to customer feedback. Fibrelite provide top class products at competitive prices and back their products up with an excellent on-site service."*

**Contracts Manager  
Dakin Contractors**







## PORTS & AIRPORTS

**FIBRELITE** 

**WE'VE GOT YOU COVERED**



# Felixstowe Shipping Port, UK

Fibrelite Supply the First F900 Load Rated Composite Trench Access Covers to One of the UK's Largest Commercial Ports



The Fibrelite 90 tonne load rated lightweight trench covers in position on the quayside



Simple and safe removal using the Fibrelite lifting handles

Fibrelite was tasked with providing a retrofit 90 tonne load rated lightweight cover that could withstand the rigours and working environment of an extremely busy commercial port.

The covers had to be F900 load rated, provide easy and safe access, be retrofitted into the existing frames and also provide security to prevent unauthorised access.

The initial approach came from the port's maintenance team who were exploring alternative replacement options for the extremely heavy and corroding steel covers that required dedicated lifting equipment, which incurred substantial financial costs with equipment, manpower and time, every time fresh water was transferred to the ship.

The Fibrelite trench covers were designed to fit directly into the existing frame, which eliminated any break out cost and greatly reduced the installation costs. The replacement trench covers are easily and safely removed and replaced by using the Fibrelite lifting handles (FL7).



Costly and time consuming operation of removing the previously installed covers



Previously both of the extremely heavy steel covers had to be removed to expose the isolation valve for the drinking water supply. Now only one Fibrelite trench cover needs to be removed

The replacement covers that Fibrelite supplied were load rated to F900 and colour coded yellow to denote fresh drinking water supply. The regional water authority had previously specified that the covers must be secured to prevent unauthorised access so Fibrelite provided a bolt down version so that the trench covers could be secured to the existing frame.

One of the port's work inspectors was quoted as saying "You will be pleased to hear that the works was completed yesterday and going forward will prove to be a huge improvement to our delivery of water to vessels".

The Fibrelite lightweight composite trench covers can be used for a multitude of applications: from ports and dockyards, industrial facilities, airports, HGV loading areas.





*Operator removing the Fibrelite securing system*

### The Benefits of Using Fibrelite's Trench Covers

- Lightweight reducing lifting and handling issues: the covers are easily removed by a two person lift, even at F900 load rating
- Bespoke covers available: covers can be designed to retrofit into existing frames, which prevents breaking concrete and substantially reducing installation costs
- Improved efficiency and productivity: quick removal and no expensive lifting apparatus required, just the ergonomically designed Fibrelite lifting handle
- Corrosion resistant
- Customised designs: covers are available in different colours, which will not fade
- Composite is lightweight, strong and unlike concrete will not crumble or crack
- Guaranteed structural performance: all covers are tested to EN124 D400 load rating (F900 is tested to BS EN 124, Class F900 using the Air BP test footprint)

# Major Northern Airport, UK



## Major UK Airport Choose Fibrelite for Safe Retrofit Replacement for Aging Concrete Recess Covers



Retrofit Fibrelite covers specified for major northern UK airport

### Project Overview

To meet the demands of an increasing population, this major airport in the North of England is undergoing major redevelopment.

Fibrelite GRP composite covers have been specified for a second installation in this development: a retrofit replacement for previous installed concrete recess covers over sewage systems, making access simpler and safer.

Fibrelite were pleased to play a part in this major project which will see the highest quality of suppliers from every industry leave their mark on this bustling facility.



Covers were showing signs of severe corrosion



Previously installed heavy concrete recess covers

### Problem

The previously installed heavy concrete recess covers were showing signs of severe corrosion, adding to the difficulty and manual handling risks when removing and replacing covers for essential monitoring and maintenance

Key considerations:

- Covers were very heavy, making them time consuming to remove as well as causing health and safety risks.
- Covers presented a trip hazard (especially during hours of poor visibility), as they did not sit flush with the ground surface.
- Visually, these covers were an eyesore and were not in keeping with the aesthetically pleasing finish desired by the client given their recent overall investment.



Covers were very heavy, making them time consuming to remove



Previously installed heavy concrete recess covers were showing signs of severe corrosion



## Solution

The Fibrelite technical engineering teams created a retrofit composite covering solution.

- Covers were manufactured to fit existing frames, cutting installation time and costs.
- Covers were manufactured and delivered within a month of PO.
- The lightweight Fibrelite covers will perform as an effective covering solution even when subjected to heavy loading pressures, allowing safe removal by hand– Fibrelite covers offer the very best strength to weight ratio available in the market today.
- Previous health and safety trip hazards created by the concrete recess covers were nullified by Fibrelite's 'fit and forget' replacement solution, as the new covers were cut precisely to sit flush from the ground surface.
- A modern finish which will not rust over time.



Covers were manufactured to fit existing frames

## Results

This northern airport now has an access solution that will continue to perform for the years to come.



Fibrelite covers allow safe removal by hand



Previous health and safety risks nullified by Fibrelite covers

# Container Terminal DCT Gdansk, Poland



Light, Strong, Inert Composite Covers Offer Simple Access Solution for Container Terminal DCT Gdańsk



Container Terminal DCT Gdańsk, Poland, the deepest container port in the Baltic sea, with the depth at app. 17 meters (Image credit: Port of Gdansk)

## Project Overview

Ports are busy highly trafficked areas, with many underground utilities that require covering, but must be frequently accessed. These covers must be strong enough to withstand container carrying vehicles, the corrosive environment (saltwater, fuel) and all weather conditions.

As part of the extension of Container Terminal DCT Gdańsk (by construction company Besix) our Polish distributor Corrimex was approached to provide a strong, corrosion-resistant, easy to remove access solution.



Access pit along edge of quay

## Problem

Along the edge of the quay, a number of trench and sealed covers were required to cover access and valve pits. These required quick and easy regular access when cargo ships docked, yet needed to withstand very heavy loads (40-90 tonnes).

## Solution

To cover the access pits, modular lightweight trench covers were supplied at a D400 load rating, allowing for safe two-person removal. For the water valve pits, sealed composite covers and frames were supplied at F900 load rating, which are light enough for safe single-person removal.

All Fibrelite covers are designed to be manually removed/replaced by either one or two people using the Fibrelite designed lifting handle(s) even at F900 (90 tonne) load rating. They also have an inherent resistance to corrosion and are hardwearing even in the harshest environment (extensively tested, see reports on our website).

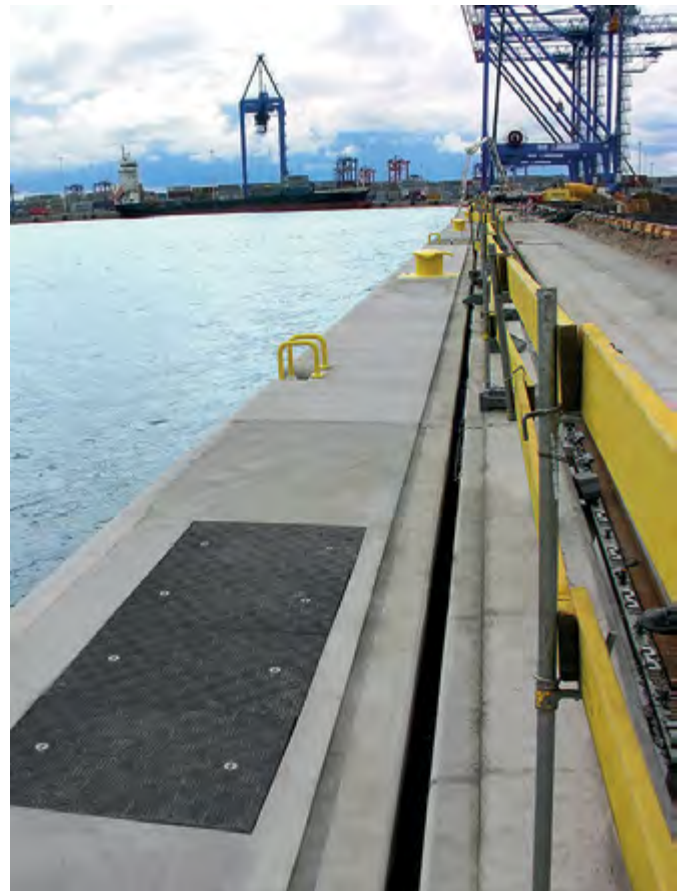

Fibrelite's trench covers covering access pit

## Results

Pawel Gross at Corrimex (our Polish distributor) said:

*"The Port owner and installer were both impressed at how light and easy to handle the covers were at high load ratings"*





*Composite frame over fresh water valve pit in concrete*



*F900 load rated sealed cover over fresh water valve pit*



*D400 load rated trench covers allowing safe manual removal*

## Fibrelite Covers Provide Heavy-Duty Lightweight Solution for Major UK Port

### Project Overview

Ports are very busy areas, where safety and efficiency are key. There are constantly ships, trucks, cranes and many more moving around with heavy loads. Underground essential service supplies must be safely and quickly accessed. The access covers must be able to withstand extremely heavy loads and stand up to the harsh corrosive environment of the port.

### Problem

As part of their renovation, a new crane was installed to load containers on and off ships. The supply cables to the crane were housed in a new underground enclosure, and needed to be regularly accessed manually for maintenance and repair procedures. The enclosure was to be set in an area of the port expecting loads of up to 60 tonnes.



Underground pit to house crane supply lines



Bespoke Fibrelite covers made to fit underground enclosure

### Solution

Fibrelite's technical team designed and manufactured trench covers to the specific dimensions and load ratings required, working from plans of the finished pit. The covers were then slotted straight into the top of the supplied frame.

### Results

Fibrelite's highly engineered composite trench covers have an inherent resistance to corrosion, meaning that they will stand up to the everyday stresses of saltwater and fuel, year after year.

The covers were manufactured at E600 load rating (load tested to BS EN 124) to withstand specified loads of up to 60 tonnes. The high strength to weight ratio of the covers means that they can be manually removed by 2 people using the Fibrelite supplied lifting handles.



Underground enclosure fitted with E600 rated Fibrelite covers



Fibrelite has recently supplied Manchester airport 44 x FM45-80 trench covers (D400 load rating) with the encapsulating aluminium frame system. Fibrelite was specified by a leading firm of architects and the covers were installed by R&M Developments.



Fibrelite's FM45 trench access covers and FL7 easy lifting aid

Proven to be ergonomically safe to remove and replace, the design incorporates two lifting points for the specially designed FL7 lifting aids. These allow the operators to remove the cover without trapping fingers or bending over thus maximising the safety of the lifting technique.

The weight is kept close to the body preventing back injury: one of the main causes of absence from work and personal injury claims. The maximum weight of the largest panel is 25kg.



Dangerous lifting technique without Fibrelite lifting aid



Safe lifting technique with Fibrelite Lifting aid

Customer quote: "I was impressed with how easy the install was and couldn't believe how light the covers were whilst still being able to hold 40 tonne loadings."

Panels can be installed on a pre-laid concrete rebate or our modular aluminium frame system which is self-keying into surrounding concrete. They can be used for a multitude of applications: from shopping centre walkways and industrial facilities to HGV loading areas in water treatment plants and power stations. No other covering system matches its easy lift, skid resistant or load carrying properties.



Fibrelite lightweight composite covers

Trench covers are a standard width of 450mm with a range of length options from 800mm to 1600mm. For larger areas of structural flooring, additional central support beams can be installed to extend the covering area.



Fibrelite covers will not corrode or crumble like concrete or metal covers







## PETROL STATIONS & FORECOURTS

**OPW** 

**DEFINING** | WHAT'S NEXT

# Major Oil Company, Belgium

## OPW Provide Long-Lasting Containment System for New Build Belgium Filling Station



OPW continue to supply major oil company with filling station equipment

### Project Overview

OPW continue to supply KPS primary and secondary contained pipework and Fibrelite tank chambers to major oil company Total in the Benelux region. This motorway site was built on both the west and east bound carriageways.



OPW provided a long-lasting containment system



Fibrelite chamber systems are fully vacuum testable and watertight

### Problem

A major oil company with large Benelux presence approached OPW looking for a reliable long-lasting containment system for a new build filling station, including Fibrelite chambers and KPS single and double wall piping. Fast installation with minimal maintenance was a priority in this project.

### Solution

In the installation the oil company used the Fibrelite S14-390-D400 chamber system and KPS piping. The chamber extensions were laminated at the factory before dispatch, reducing the onsite installation time which was a priority. Even with the extensions they are fully vacuum testable and watertight.

KPS single wall and double wall piping provides a safe, easy-install solution requiring the minimum possible number of welds. KPS double wall piping requires fewer welds than any other system available, as the compact KPS fittings weld both walls of a double wall pipe simultaneously, again reducing installation time.

### Results

Fibrelite laminated chamber extensions and KPS' easy install piping allowed for a fast installation.



Fibrelite sumps and KPS piping reduced installation time



## OPW Provide a Long-Lasting Solution for Earthquake-Prone German Site

### Project Overview

OPW products work together across a site in earthquake prone Messkirch, Germany to provide the client with a solution that would meet German approval whilst limiting disruption and damage from earthquakes, this consisted of Fibrelite tank chambers and KPS piping.



Fibrelite tank sumps and KPS piping provide a complete secure system

### Problem

Restrictions for underground rigid steel and GRP piping systems in earthquake prone areas meant that the replacement had to have flexible components to prevent the products breaking and become damaged when an earthquake occurs. In Germany, approval of the construction material and type of construction is required. The products had to be certified by the 'Deutsches Institut für Bautechnik' (DIBt) who grant national technical approval.



KPS semi flexible pipe system is unaffected by earth movements

### Solution

KPS piping was installed and connected to Fibrelite tank chambers as the KPS semi flexible pipe system is unaffected against earth movements, whilst meeting the approval of the DIBt making it the perfect solution providing a flexible long-term secure system.



OPW provided a complete sealed system for ENI Germany

### Results

OPW supplied ENI Germany with a long lasting underground system capable of withstanding earth movements whilst meeting the German construction approval.

# Major Oil Company, Spain



OPW's Pre-Fitted Fibrelite Remote Fill Sumps & KPS Piping Simplify Installation for Major Oil Company in Spain



A suite of Fibrelite and KPS products eliminated potential installation issues and streamlined site construction at this Spanish site



OPW products work together to create a complete sealed system

## Project Overview

A suite of Fibrelite and KPS products was adopted for this Cádiz filling station to eliminate potential installation issues and streamline site construction, providing a trustworthy long-term solution requiring minimal maintenance. Key to this project was an easy-install replacement for previously used conventional cast iron spill chambers.

Following the success of this installation, the oil company adopted Fibrelite below ground remote fill sumps as standard for all Spanish sites.



OPW products provide a fit-and-forget solution, requiring minimal maintenance for the life of a site

## Problem

Previously in Spain, the oil company had been installing traditional cast iron spill chambers, one per fill line. These required time-consuming exacting installation on site, relying on local installer's expertise.

To be installed, chambers had to be perfectly aligned to the threaded metallic termination of the pipe system beneath before attaching, often requiring a metal frame and support beneath pipes. Any errors or misalignment during installation would result in a non-liquid-tight system, leading to potential water ingress and fuel egress.

To access fill points required unsafe lifting techniques, the position and weight of the cast iron covers requiring users to stoop, risking back and finger injuries. This was exacerbated if covers corroded over time with exposure to water and fuel which could cause fusing of covers to chambers or leaks. The metal surface of the covers was also slippery when wet, causing a slip hazard for station users.

A long-term liquid-tight solution for all sumps and piping was required.



Previously used cast iron spill chamber





Cast iron chambers often have to be fixed in a frame and piping supported (pictured: different site to show possible frame configuration)

**Solution**

The oil company, OPW's Spanish distributor, and OPW, have a long-standing relationship, developed over many years of working with Fibrelite and KPS products. Following the recommendation of their Portuguese branch, our Spanish distributor was approached for a solution.

After considering site requirements, Fibrelite S2-360 OFD BPP K2 sumps were specified. These arrive at site preassembled, installation as simple as attaching the two fill lines to those emerging from the sump, without the need for frames or supports. It's also a more compact system than previously installed, each sump containing two fill lines or one fill and one vapour recovery line. This increases speed of fuel delivery as there are only half the number of covers to remove, each one topped by a lightweight Fibrelite composite cover enabling fast safe removal. Fibrelite covers also provide a safe walking surface for station users due to their unique anti-skid tread pattern and are made from an inert composite material which will not corrode with exposure to fuel or water.

These factors combine to result in a huge reduction in installation time while eliminating the risk of leakage due to incorrect installation or corrosion.

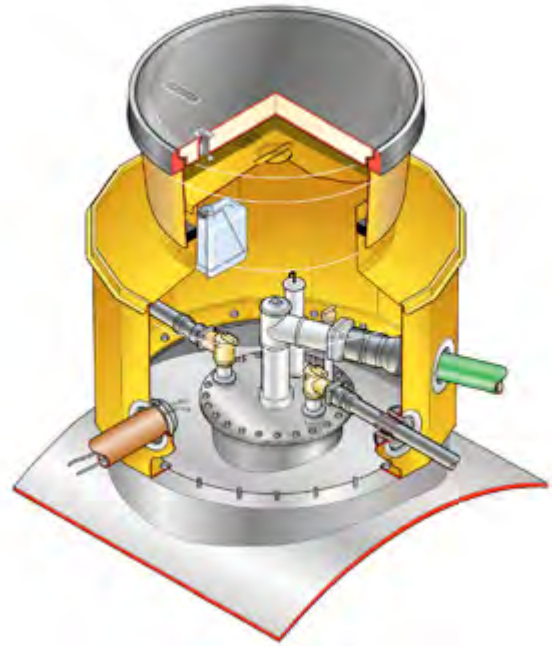

Fibrelite tank sumps are vacuum testable, ensuring liquid tightness



Fibrelite tank sumps are completely liquid-tight

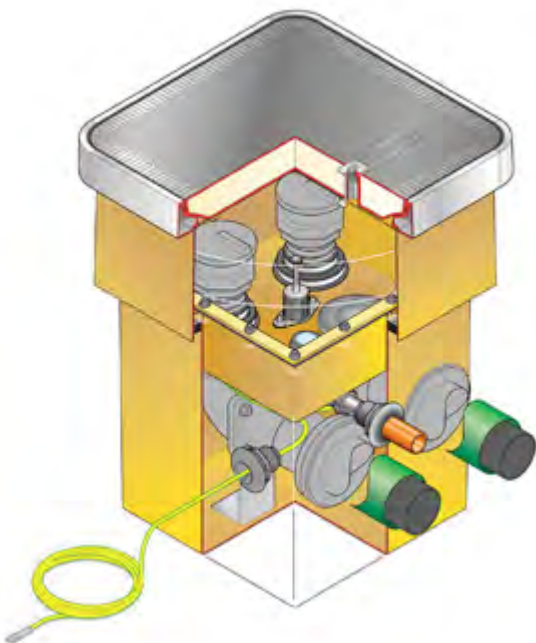

Fibrelite below ground remote fill sumps are factory assembled and tested (corner sliced to show internals)

For piping, KPS was chosen to further simplify installation. 125/110mm conductive piping was used for fill lines and 63mm conductive for suction, vapour recovery and vent lines. Designed for easy installation, KPS' compact fittings require the minimum welding time possible. In fact, KPS double wall fittings require less welds than any other system available. KPS piping can be trusted to perform year after year, with approvals from DIBT Germany, EN 14125, UL 971, ATEX 137 and EN 13463-1 as well as a number of other country and fuel specific standards.

For this site, it was decided to use a full range of Fibrelite and KPS products to simplify supply, control lead times and ensure quality and traceability. All products were supplied by an experienced local distributor whose stock comes directly from OPW's manufacturing facilities (all OPW products are manufactured at OPW facilities to ensure quality and enable quick design-to-delivery capabilities). This site used Fibrelite tank sumps, remote full sumps, dispenser sumps and covers (all Fibrelite sumps are vacuum tested before leaving the factory).



*Fibrelite covers provide a safe walking surface for the public and tanker drivers due to their unique anti-skid tread pattern*



*Fibrelite below ground remote fill sumps only require two pipe welds to install*

## Results

Construction of this site went far faster than previous sites where cast iron spill containers were used. Together, the Fibrelite sumps and KPS piping created a high-performance low-maintenance long-term solution which increased the overall efficiency and safety of the station.

The oil company has now adopted this solution as standard in Spain. Fibrelite and KPS products are also specified by the company's UK and Portuguese branches.

Innovation is one of OPW's core values, holding more patents than any other equipment manufacturer. Backed by their parent company Dover Corporation, OPW continually develops and refines its product range to solve customer's current and future problems. The products in this case study are just a few recent examples.



# Petro Systems Management, Ireland



## Petro Systems Management Upgrade from Steel to KPS Plastic Pipe for All New Installations

### Project Overview

Petro Systems Management has upgraded from using steel pipework in their installations to using KPS conductive plastic piping, enabling simple, fast, long lasting installations, especially when used in conjunction with Fibrelite tank sumps and seal kits as pictured here.



*Petro Systems Management has upgraded from steel pipework to KPS*



*KPS piping, Fibrelite sumps and Fibrelite pipekits enable quick liquid-tight installations*



*Petro Systems Management's first site using KPS piping*

### Problem

Petro Systems Management traditionally installed petrol station sites in Ireland with steel pipe. With an eye on the future, and to help their installation team, they wanted to move towards using plastic conductive pipe for forthcoming installations, making the switch from the old, heavy, labour intensive, traditional method of working with steel pipes.



*When the first site was under construction, the OPW team were on hand to offer onsite installation and guidance*

### Solution

Petro Systems Management already used OPW gauges and were familiar with the OPW team and the quality of OPW products; so when upgrading to plastic pipe (the now industry standard), they chose KPS.

OPW provided classroom and practical training at their offices before the project started to familiarise the installation team with the products and the theory behind electrofusion welding before going on site.

When the first site was under construction, the OPW team were again on hand to offer expert onsite installation training and guidance for all the OPW products used including KPS pipes and Fibrelite sumps.

## OPW Products Work Together to Provide LUKOIL with a Long Lasting Below Ground Containment System



Fibrelite S7-390 GRP tank sumps require minimal maintenance and provide maximum protection (Photo taken prior to KPS pipe installation)



KPS pipework and Fibrelite tank sumps ensure a complete sealed system

### Project Overview

OPW provided LUKOIL, a major Russian based oil company, with an easy-install underground containment system including KPS pipework and Fibrelite tank sumps, for a new build filling station in Bulgaria. Ease of access, longevity and the speed of installation were of the highest importance.



Technical support and installation training was required on site to complete the project within its tight timescale

### Problem

LUKOIL required long lasting and reliable containment for a new build filling station including associated internal equipment (pipework, valves, covers and probes) that would perform for the lifecycle of the site with minimal maintenance.

The project had a tight timescale for completion so a quick installation was a priority. As a result, on-site technical support and installation training were necessary.

### Solution

OPW supplied LUKOIL with a sustainable solution which ensures complete containment and conductivity for the lifecycle of the site. Throughout the installation, an OPW product expert provided on-site technical support and installation training, enabling the filling station to be finished within the desired timeframe.

In the installation, OPW used Fibrelite S7-390 GRP (glass reinforced plastic) tank sumps which are strong, non-corrosive and require minimal maintenance during their working life. All sumps are vacuum tested in one of OPW's facilities for tightness, ensuring against water ingress and providing maximum protection for fuel lines, while allowing easy secure access for fuel delivery, maintenance and inspection.



KPS pipework and Fibrelite tank sumps ensure a complete sealed system





*OPW 14NL angled check valve allows manual fuel flow control*

63mm single-wall KPS piping was used to connect the system, providing a safe, easy-install solution requiring the minimum possible number of welds. KPS piping, like Fibrelite sumps, can be fully conductive and ensures safety in the eventuality of sparks or leaks.

OPW's industry-leading Fibrelite 40 tonne load rated manhole covers, provided a watertight, anti-slip, and easily removable covering solution over the tank sumps. These will also be subject to heavy traffic flow so durability and a safe walking and driving surface are essential – just some of the key reasons why Fibrelite's composite covers are the preferred choice of oil companies worldwide.

## Results

OPW supplied LUKOIL with a reliable containment system that will perform in the toughest of conditions for the lifecycle of the site. The installers, along with LUKOIL, were impressed with the speed, ease, and support around the installation as well as the quality of OPW's products. Following this successful installation, LUKOIL has continued to place repeat orders with OPW.



*OPW's easy-install Fibrelite below-ground containment can be fit and forgotten for the lifecycle of the site*

# Fuel Retailer, Romania

OPW Products Work Together to Provide Fit and Forget Above Ground Remote Fill Solution



Romanian Fuel Retailer specifies OPW products for series of installations

## Project Overview

A Romanian oil company approached OPW to provide an easy to install, reliable above ground fill point solution including associated internal equipment (pipework and fill caps) that would perform for the life of the site.

## Problem

They required an above ground remote fill sump which would allow safe fast access to fuelling points for tanker driver, while protecting against unauthorised access or water ingress from above or below ground. Four fill points and one vapour recovery were specified, with fill caps and an easy-install piping solution to run to fuel tanks. For safety, all items needed to be conductive to prevent static electricity build-up.

Consideration was also given as to the accidental yet inevitable fuel drips and spills that occur when fuelling.

## Solution

Industry first Fibrelite GRP above ground remote fill sumps provided a great alternative to traditional galvanised steel. The composite material is impervious to corrosion from exposure to water and fuel, meaning it will remain liquid tight for the life of the site, vacuum testable like all Fibrelite sumps.

Designed with a secondarily contained spill tray to catch fuel spills and drips, the system includes an earth cable kit to ground the pipework. The two-leaf watertight hinged door provides lockable easy access to the fill points for the tanker driver. On this site, the door was padlocked for security instead of each individual fill cap, allowing for faster fuel delivery. Models are available in three sizes to accommodate from three to seven fill and vapour recovery lines.

Supplied with high quality Fibrelite Viton pipe seals which will not deteriorate when exposed to fuel and vapours, the above ground remote fill's simple single piece design provides a large working space to install pipework inside the sump before the spill container is installed. Installer friendly KPS piping was used to connect the fill points and remote fill. Compact KPS fittings weld both pipes simultaneously wherever connections are required, reducing installation time.

To complete the containment, the OPW tight-fit top-seal caps were installed on top-seal adaptors, which prevent gasoline vapours from escaping and to prevent water, dust and debris from entering the tank. The OPW 634TT seal cap is heavy duty and corrosion resistant, with a body made of Duratuff to help eliminate rust and oxidation for a long, maintenance-free life. The toggle lever distributes downward pressure to compress its Buna-N gasket evenly, assuring a positive, water and vapour-tight seal. The 634TT can be locked with a padlock or wire seal.

Together, the Fibrelite sump, KPS piping and OPW fill caps formed a contained and conductive system, preventing leaks or static electricity build up.



Installer friendly KPS piping used to connect fill points to tanks



GRP composite material is impervious to corrosion from water & fuel



## Results

OPW provided a fit-and-forget solution which will endure for the life of the site while reducing installation time by supplying all products from a single source, and reducing number of welds required with easy-install KPS piping.

The fuel retailer is continuing to roll Fibrelite above ground remote fills out across a series of new sites.



*OPW heavy duty corrosion resistant seal caps*



*Vacuum testable GRP sump prevents water ingress from above or below ground*



The unique offset sump/corbel arrangement allows for bi-lateral pipe exits



All integrated KPS fittings weld both pipe walls simultaneously

**Project Overview**

BP approached OPW to provide a simple fill solution for a selection of their UK sites. In response, OPW developed a new range of Fibrelite GRP below ground remote fill systems.



Fibrelite's below ground remote fill systems with factory fitted/tested dual contained and conductive KPS pipework



Below ground remote fill systems incorporating a sump and offset corbel with alternate pipe exit positions

**Problem**

Due to site layout constraints, BP required a below ground remote fill with opposing pipe exit positions to ensure consistent fill layouts for tanker deliveries and simplify the installation reducing installation time and costs. Consideration was also given to the most efficient petrol pipework option.

**Solution**

OPW developed their existing range of Fibrelite below ground remote fill systems to incorporate a sump and offset corbel with alternate pipe exit positions in line with BP's requirements. The new sump and corbel utilised some items from the existing product range to deliver a unique while cost effective solution. This new product was made available in line with the start of the new construction programme.

The new below ground remote fill systems are factory fitted with dual contained KPS pipework for the fills and single wall for the stage 1 vapour line. Systems are fabricated in accordance with the supplied fuels layout drawing. Pipework is terminated above a secondary contained spill container with BP specified fill caps/adaptors and vapour recovery unit.

This environmentally friendly system is supplied ready to go with the earth bonding pre-fitted and both the pipework and dual contained GRP containment system factory tested prior to shipment. Once the systems are positioned on site the pipe contractor simply makes a fusion weld connection to the pipe tails on the outside of the sump.

Installer friendly KPS petrol piping was used to connect the remote fill sumps to petrol tanks and dispenser sumps. Where connections are required, compact KPS fittings weld both walls of a double wall pipe simultaneously, reducing installation time. Conductive double wall piping ensures safety in the eventuality of sparks or leaks.





The fully conductive below ground remote fill systems are supplied with a non-slip working platform for the tanker driver to stand on



Factory fitted with dual contained KPS pipework for fills and single wall for stage 1 vapour line



New sump and corbel utilised some items from existing product range to deliver a unique while cost effective solution

## Results

The new Fibelite remote fill sump systems are now being specified for a number of BP's UK sites. These systems ensure consistent fill layouts for tanker drivers which together with KPS piping enables faster, more efficient site construction, reducing cost while creating a safe sealed system of the highest standard available.

## Fibrelite Supply Below Ground Remote Fill Point Sumps and Covers to BP Sites in Portugal



Site being upgraded with Fibrelite's fully conductive below ground remote fill sumps, covers and KPS conductive double wall fill pipe

Fibrelite's vacuum testable below ground remote fill sumps and 25 tonne rated composite covers have been specified by BP in Portugal.

### Factory Assembled and Easy to Install

Fibrelite's remote fill sumps are pre-installed with KPS double wall pipework at their UK factory and vacuum tested prior to shipment to site. Secondly contained and fitted with all Viton seals, Fibrelite's wide range of remote fill sumps are suitable for blended fuels.



Recently upgraded site with Fibrelite's 600mm sq. 25 tonne load rated covers (FL60)

### Testable Containment, Consistent Structural Integrity

Fibrelite's high quality one-piece moulded tank sumps and remote fill sumps are fully conductive and testable to ensure a watertight installation. Designed and manufactured to withstand high groundwater pressure after installation for the lifetime of the site.



Secondarily contained Fibrelite remote fill sumps

### Features include:

- Internal spill tray
- Complete conductivity
- Drain back feature that allows the fuel spilled to be diverted back to the interceptor
- Pre-installed pipework and is pressure tested by the Fibrelite team
- Pipes can be arranged in any combinations



Fibrelite remote fill sumps and KPS conductive double wall fill pipe





## PETROL STATIONS & FORECOURTS



MAKING FUEL FLOW SAFELY



# Wholesaler Petrol Station, Manchester, UK

Custom 10m KPS Piping Reduces Cost and Build Time for New Build Wholesaler's Petrol Stations



North England site under construction



KPS formed bends below fill point

## Project Overview

A leading membership-only wholesaler approached OPW to provide an easy to install, reliable, fuel piping solution specifically adapted to their station configuration. Safety during and after installation were of utmost importance.



Client had a distance of 10m between pump islands

## Solution

At the installer's request, OPW manufactured and supplied 10m lengths of 75/63mm KPS piping to run between the dispensers instead of the standard 5.8m lengths, allowing a faster more efficient installation (KPS pipe is also available in coils).

Where connections are required, compact KPS fittings weld both walls of a double wall pipe simultaneously, again reducing installation time. Conductive double wall piping ensures safety in the eventuality of sparks or leaks.

OPW 10 series emergency shut-off valves were installed on fuel supply lines beneath dispensers at grade level to minimize hazards associated with collision or fire at the dispenser. If the dispenser is pulled over or dislodged by collision, the top of the valve breaks off at the integral shear groove, activating poppets and shutting off the flow of fuel.



All integrated double wall KPS fittings weld both pipe walls simultaneously



KPS pipe is also available in coils





10m lengths of custom 75/63mm KPS straight pipe allowed fast installation without the need for a welding socket in middle

### Problem

With a distance of 10m between pump islands, if the installer had used traditional 5.8m piping, a welding socket in the middle would have been required, adding cost and time to the install. Where junctions were required, speed and safety were of paramount priority.

In case of collision with or fire at one of the dispensers once the station was completed, a solution to cut off fuel flow was required.



KPS bends below fill point



KPS' compact fittings allow for easy, fast welds

### Results

OPW enabled a faster more efficient pipe installation, reducing the number of welds required, and simplifying those that were.

Custom KPS piping can be produced in a comprehensive variety of lengths to suit the configuration and specification of the site.

The wholesaler is now rolling out KPS piping and OPW shear valves as standard across all their sites. By working directly with the installer and client, OPW has considered future requirements and holds stock locally to enable quick delivery whenever required.

# Tatneft, Russia

One Of Russia's Largest Oil Companies Switches from Steel to KPS Plastic Piping



Tatneft owned petrol station in Moscow, Russia



KPS piping is a modern alternative to outdated steel piping

## Project Overview

Russian OPW installer ALFA LEVEL GRUP, who work with Tatneft have switched from using outdated steel pipework in installations to using KPS conductive plastic pipe with OPW shut-off valves.

## Problem

The installer traditionally used steel piping in installations on sites across Russia but had begun to find working with heavy steel pipes outdated. This is due to the time installation takes, the customer was looking to move towards the now industry standard of using plastic pipe for fuelling, combined with OPW shut-off valves.

## Solution

The installer ALFA LEVEL GRUP presented Tatneft with KPS piping as a modern solution to steel piping, Tatneft decided to upgrade to plastic conductive piping which requires the minimum possible number of welds for this and forthcoming installations thanks to the safe, easy-install solution it provides.

## Results

Tatneft has successfully upgraded to the industry standard of using plastic pipe for fuel alongside OPW shut-off valves, they now have a long-lasting solution that reduces previous installation time and simplifies fitting for the team.





*KPS piping reduces installation time*



*KPS piping combined with OPW shut-off valves creates a reliable fuelling solution*

# VSE DLA AZS, Russia

Russian Installation Team Adopts KPS Piping with an Eye Towards the Future



*KPS conductive plastic pipe is favoured by Russian installer*



*Theoretical and practical training was provided by KPS*

## Project Overview

Russian KPS installer VSE DLA AZS has upgraded from using heavy outdated steel pipework in installations to using long lasting KPS conductive plastic pipe.



*The customer now has a long-lasting KPS solution that will continue to perform year after year*

## Problem

The customer who traditionally installed heavy, labour intensive steel pipes across sites in Russia were looking to upgrade to the now industry standard of plastic conductive piping for future installations. The steel piping was challenging to install due to its weight, the pipe also begins to rust over time.

## Solution

KPS provided theoretical and practical training for the VSE DLA AZS installation team before the project started to ensure they felt confident when installing a new product and so that it was done correctly. The customer has now upgraded to a lightweight new easy install plastic piping.



*Training enabled a confident quality installation*

## Results

The customer now has a long-lasting solution that will continue to perform year after year, the theoretical and practical training provided by KPS enabled a confident quality installation to be carried out by the VSE DLA AZS team.





KPS provided long-term plastic piping system for pressure lines in Kazakhstan

### Project Overview

Sinooil approached OPW for a simple conductive piping system for pressure lines on a site in Kazakhstan. The site had a long distance between tanks and dispensers and emergency valves were required.



Sinooil required a solution that allowed emergency valves to be installed under dispensers

### Problem

The customer required an easy install solution with minimal connections due to the long distance between the tanks and dispensers. The piping system also needed to allow for emergency valves to be installed under dispensers, and for suitable join points for submersible pumps.



KPS easy install piping reduces installation time

### Solution

KPS' conductive double wall pipe system had several key features for this project:

- Minimal connections required between sumps and dispensers
- Compact solution allowing emergency valves to be installed under dispensers and for suitable join points for submersible pumps, due to pipes entering directly below dispensers
- Easy-install fittings: KPS double wall fittings are the only available to weld both pipe walls at the same time

### Results

KPS easy install piping enabled the installation to be completed within two days.



The KPS compact solution allowed for emergency valves to be installed under dispensers









## PETROL STATIONS & FORECOURTS

**FIBRELITE** 

**WE'VE GOT YOU COVERED**

## Fibrelite's Watertight Manhole Covers Help Protect Petrol Stations Against Flash Floods in Istanbul

### Project Overview

Fibrelite provided Tora Petrol with fully watertight, GRP composite manhole covers which help protect fuel tanks across Turkey's Marmara region. These proved invaluable during the July 2017 floods, where Fibrelite's composite manhole covers minimised fuel tank damage by preventing surface water ingress. The Marmara region is home to Turkey's largest city, Istanbul.



Some petrol stations in Istanbul were submerged during the July 2017 floods



Fibrelite's watertight GRP manhole covers are installed at petrol stations across Istanbul and surrounding areas

### Problem

Turkey's Marmara region is the most populated region in the country, despite having the second smallest area. Its dense population means that there is a lot of pressure on petrol stations. To avoid unwanted disruption from refuelling and maintaining underground fuel tanks, they need to be quickly and safely accessed through manhole covers. These covers also must be able to withstand the everyday stresses of constant traffic, including vehicles with heavy loads; whilst proving a safe walking and driving surface.

The Marmara region can be prone to heavy rainfall due to its surrounding seas, high mountain ranges, and variations in height over short distances. Some petrol stations in the region therefore specified manhole covers which could withstand the threat of flooding. This is vital, as if surface water leaks through the manhole covers, there would be a substantial risk of fuel contamination which is both very costly and time-consuming to rectify. Resistance to corrosion from water and fuel was crucial to this as it can cause a less than perfect fit, allowing water ingress.

### Solution

Fibrelite provided Tora Petrol with watertight composite manhole covers at a number of petrol stations across the Marmara region. These were put to the test in July 2017 when torrential rain swamped transport networks, buildings, and offices, causing widespread flooding across Istanbul and surrounding areas. This left sections of the city underwater, including petrol stations both on the E5 highway and in the coastal area. Despite the floods, Fibrelite's watertight manhole covers prevented any ingress of surface water into chambers above the fuel tanks.

As well as being lightweight – typically a third of the weight of an equivalent-size cover produced in metal or concrete, Fibrelite manhole covers eliminate the risk of back injury and crushed fingers with their ergonomically-designed lifting aid, which enables safe lifting from waist height. The covers also provide a safe walking and driving surface even when wet, which has been tested to be equivalent to a modern high-grade road surface. Manufactured using a specialised composite material, they will not corrode over time unlike metal and concrete, meaning that they will perform for the life of each site.



Fibrelite's covers prevented surface water ingress into chambers above the fuel tanks



## Results

Fibrelite provided Tora Petrol with a cost-effective, sustainable, composite solution, that has made petrol stations in the Marmara region more resilient, efficient and safer.

“Thanks to Fibrelite, for preventing any underground storage tank damage and for protecting our customers from any pecuniary loss and intangible damages during the heavy rainfall that caused flooding in Istanbul last July. It is really great how not even a single raindrop went into the fuel tanks while all roads, subway stations, and petrol stations were affected by hailstones and heavy rain. Let’s just imagine the worst case, if water would have penetrated the underground tanks, we would have had to remove the product and complete gas freeing by disassembling all fittings and pipes connected to the contaminated tank which would have left the concerned petrol station out of service for a significant amount of time. This would have caused time and economic loss, plus a bad customer experience, causing potentially loyal customers to slip away. Instead, we received positive feedback from petrol stations and their customers who were grateful to have fully watertight composite manhole covers. So again, thanks a lot Fibrelite!”

**Ertum Tufekci, Board Member, Tora Petrol**



*Fibrelite composite covers prevent surface water ingress into chambers*

LUKOIL Specify Fibrelite Covers for National Update Programme to Eliminate Health and Safety Risks



Fibrelite covers installed at a number of LUKOIL sites to replace failing cast iron covers



The previously installed cast iron manhole covers had rusted allowing water ingress

## Project Overview

A national LUKOIL Bulgaria EOOD project to replace old heavy hinged cast iron manhole covers on forecourts with Fibrelite lightweight GRP composite manhole covers. This project was supplied by SisCo-M Ltd and undertaken due to corrosion and deterioration of the previously installed metal covers, which were becoming increasingly dangerous for operators and site owners.

## Problem

LUKOIL's previously installed metal manhole covers had become rusted over time, with hinge mechanisms beginning to fail and covers becoming unsafe for operators and site owners to remove and replace. The seal, around the covers were also damaged allowing water ingress. A safe long-term liquid-tight solution was required.



Failed seal due to rust allowing water ingress into chamber

## Solution

Fibrelite provided LUKOIL with corrosion-free lightweight composite manhole covers. Being watertight and safely manually removable, these covers were the perfect solution to solve LUKOIL's manual handling challenges.



Lightweight new Fibrelite FL76 covers installed in Bulgaria for LUKOIL



## Results

Fibrelite FL76 covers require minimal maintenance and perform for the life of the site, making them a “fit and forget” solution. A rapid design to delivery process, and a responsive local distribution network also guarantee fast turnaround times.



*Fibrelite watertight manhole covers helped LUKOIL to eliminate water ingress*

## OPW Create Bespoke Chamber Bonding Solution for Shell, Reducing Installation Time and Cost



*Fibrelite tank sumps bonded to existing tanks using bespoke bonding system*



*Previously installed chambers had corroded, allowing water ingress*

### Project Overview

Existing steel tank upstands on this site were not wide enough to facilitate a traditional bolted connection.

OPW's UK engineering team created a bespoke chemical bonding system to attach GRP Fibrelite tank sumps to the existing upstands, eliminating the need for additional work and expensive adaptor plates.

### Problem

Shell required a retrofit watertight solution to replace previously installed tank sumps / chambers fitted to existing tank upstands without replacing the tanks.

The main problem for this installation was that the old tank upstands were too small for the traditional bolt down tank sumps / chambers.



*Shell required a retrofit watertight solution*

### Solution

OPW's Fibrelite team came up with a solution to chemically bond the GRP square chambers onto the old tank upstands.

The OPW Fibrelite site team used an epoxy putty compound to lay onto the tank collar before carefully placing the chamber on top, bonding the chamber to the upstand. Preparation of surfaces before bonding was key.



*At this site, the old tank upstands were too small for the traditional bolt down chambers tank sumps / chambers*



*OPW's Fibrelite team came up with a solution to chemically bond the GRP square chambers onto the old tank upstands*



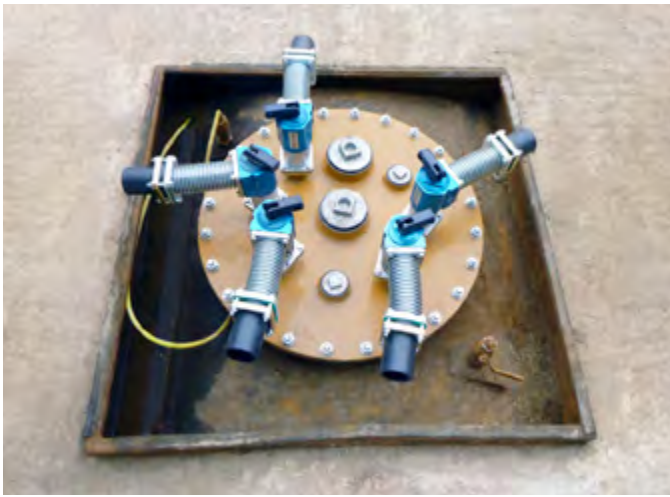

Tank surface being prepared for bonding



Epoxy putty compound



The Fibrelite site team conducted a vacuum test on site after the install



Fibrelite tank sump mounted on old tank upstand

## Results

Bonding the chambers directly onto existing tank upstands saved Shell time and money on installation while providing a fully watertight chamber system, which will endure year after year.

The site team conducted a vacuum test onsite after the install to ensure water tightness of the chambers.



Preparation of surface for putty

## OPW Produces Retrofit Fibrelite Sumps to Support BP's AdBlue UK Program



BP required retrofit chamber systems



OPW developed bespoke Fibrelite dispenser sumps for BP

### Project Overview

OPW was approached by BP who required retrofit chamber systems which could be fitted to AdBlue dispensers at various petrol stations across the UK within a tight timeframe.



Fibrelite products enable a more efficient site construction



All sumps are vacuum tested before dispatch

### Problem

BP required a retrofit watertight chamber system which could be fitted to a GVR Frontier and GVR 700 AdBlue dispenser pump. In some cases, the sumps needed to fit within the HGV raised kerb island within a tight timeframe.

### Solution

OPW developed bespoke Fibrelite dispenser sumps and metal work to incorporate dispenser pumps, in line with BP's requirements. The sumps had to account for potential shallow burial depths and existing island width, they also had to be adjustable to accommodate site constraints. All sumps are vacuum tested before dispatch to ensure that they are truly watertight.

### Results

The bespoke dispensers have now been installed at over 40 BP stations (90 systems) across the UK, enabling a faster, more efficient site construction, reducing cost whilst providing a watertight system.





*Ideal for new and retrofit installations*

Fibrelite has achieved another industry “first” by developing a brand new GRP above ground fill sump range. Through collaboration with a global major oil company, the first retrofit model was designed to replace existing galvanised steel fill boxes and connect to existing underground pipework. The first installation has been completed by Kwong Ngee Engineering PTE Ltd in Singapore. As part of an upgrade and modernisation program Fibrelite used its high-technology RTM production methods to create a range of high quality fibreglass liquid tight equipment for their Singapore network.



*Fibrelite tank sumps being installed*

## Testable Containment, Consistent Structural Integrity

The S22SH-2/AGF model is designed to contain up to seven remote fill lines and one vapour recovery stage VR1b. The highly innovative design provides secondary containment and the upper spill tray can contain up to 83 litres of discharged fuel. Fibrelite's above ground remote fill boxes are available in 3 sizes and are designed to accommodate from 3 to 7 fill lines and available for new installations or retrofit situations.



*Fibrelite's S22SH-2/AGF above ground remote fill box*



*Fibrelite's fuel resistant Viton entry boots*

## Long Working Life - Tried and Tested Reliable Performance

Fibrelite's range of above ground remote fill sumps offer a great alternative to traditional galvanised steel. Designed with a secondarily contained spill tray to catch fuel spills and drips, the system includes an earth cable kit to ground the pipework and the watertight hinged double doors provide secure easy access to the fill points for the tanker driver. Fibrelite will be expanding this new range of products in the coming months.

Coupled with Fibrelite's fuel resistant Viton entry boots this presents a great environmental solution and a major health and safety step forward. Supplied with Fibrelite's high quality Viton pipe seals which will not deteriorate when exposed to fuel and vapours. The simple two piece design provides a large working space to install pipework inside the sump, before the top section is installed.

Products were supplied by Fibrelite's distributor Kwong Ngee Engineering PTE Ltd in Singapore.

## Qatari Oil Company Awards Fibrelite Sole Supplier Status for Tank and Dispenser Sumps to Handle Desert Climate Conditions



Fibrelite tank and dispenser sumps specified by Qatari oil company



Fibrelite pipe entry sealkits are easy to install, vacuum testable and flexible to allow for ground and pipework movement

### Project Overview

Fibrelite has been awarded sole supplier status by a Qatari oil company for tank and dispenser sumps with pipe and cable sealing kits to withstand the tough local climate and installation conditions.



Fibrelite S14-390 tank sumps under installation



Fibrelite EL-G-E500 dispenser sumps ready for concreting



Vacuum testable Fibrelite pipe sealkits form watertight seal

### Problem

The client had experienced issues with previously installed equipment (tank and dispenser sumps) due to the constant extreme temperatures during summer months (up to 50°C+).

Water ingress issues had also been a problem at locations near the coast due to the high pressure of the surrounding water table on the enclosures and a highly corrosive environment.

### Solution

Fibrelite's vacuum testable GRP tank and dispenser sumps provide a strong, hard-wearing, liquid-tight containment solution. Unlike PE, GRP is not detrimentally affected by high temperatures and does not lose its rigidity or shape, making it ideal for installations like this one and similar across the Middle East and African regions.

Many installations have persistently high water tables, as at the coastal locations of this client. Fibrelite's vacuum testable tank and dispenser sumps are highly effective in preventing water ingress and subsequent damage to equipment and possible water contamination to fuel.

Fibrelite supplied through our local partner RUMCO in Qatar, who provide installation and testing services to retail fuelling clients in Bahrain and Qatar, including vacuum testing during installation to ensure liquid-tightness before back-filling.





All Fibrelite sumps are vacuum testable during and after installation



Fibrelite dispenser sumps are highly effective at preventing water ingress



Fibrelite pipe entry sealkits are easy to install, vacuum testable and flexible to allow for ground and pipework movement

## Results

Fibrelite produces high quality, high strength one-piece moulded GRP components with a smooth surface for easy and safe manual handling and installation. All products are designed and manufactured to withstand the toughest environmental and climatic conditions for the lifetime of the site.



Fibrelite's lightweight, watertight manhole covers and GRP tank sumps have been specified by a leading oil company in the UAE



The deep installation required a robust corrosion resistant watertight solution

### Problem

The deep installation required a robust corrosion resistant watertight solution to withstand the high pressure of the surrounding tidal water table and highly corrosive environment.



Fibrelite's vacuum testable tank sumps highly effective in preventing water ingress

### Solution

Many installations have persistently high water tables and Fibrelite's vacuum testable tank sumps are highly effective in preventing water ingress and subsequent damage to equipment and possible water contamination to fuel.



Fibrelite tank sump system with KPS pipework provides a best in class offering



Fibrelite tank sump system with pipework attached using Fibrelite pipe entry seal kits, forming a watertight seal

### Results

The finished installation provided the customer with a completely watertight, robust, maintenance free installation.

Fibrelite manhole covers and GRP containment systems are lightweight, durable and very strong, All Fibrelite's GRP products are manufactured using high-technology RTM production methods to create a highly engineered monolithic composite product.





*Fibrelite tank sump being vacuum tested on site*

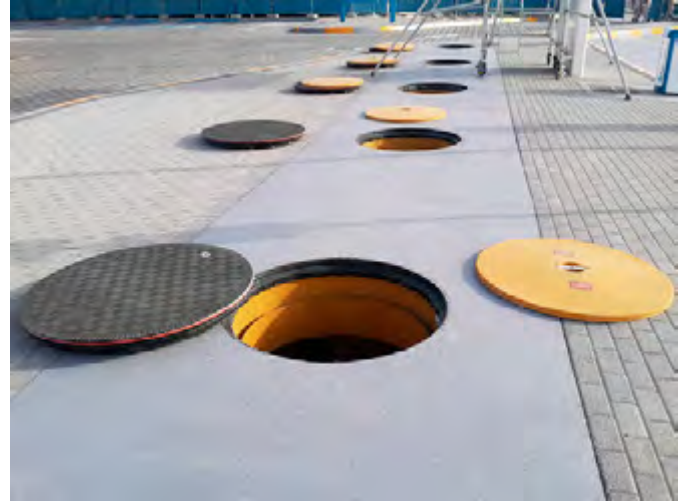

*Completed installation with Fibrelite's FL100 (40"/1020mm) watertight lightweight covers*

## BP, Auckland, New Zealand

Fibrelite Supply GRP Tank Sumps to a BP Connect Site in Auckland, New Zealand



*Fibrelite sumps are vacuum testable ensure watertightness*



*Strong, robust and lightweight chamber systems*

### Project Overview

BP New Zealand has standardised the use of Fibrelite tank sumps across its network. A BP connect site was upgraded with new tanks and Fibrelite's S15CR-390 tank sump with manhole cover. Fuel Installations Ltd, the contractor, installed and vacuum tested the Fibrelite products.

Fibrelite products were supplied by Petroleum Equipment Services, based in Auckland New Zealand.



Fibrelite's Fibreglass Tank and Dispenser Sumps Specified by a Leading Oil Company in China



Site under construction

Fibrelite's vacuum testable fibreglass tank sumps and dispenser sumps have been specified by a leading oil company in China. As part of a new to industry construction program Fibrelite used its high-technology RTM production methods to create a range of high quality fibreglass equipment for the growing Chinese market.



Fibrelite tank sumps (S14-390) being installed

## Testable Containment, Consistent Structural Integrity

Fibrelite's high quality one-piece moulded tank sumps have a smooth finish for easy handling during installation. Designed and manufactured to withstand high groundwater pressure after installation for the lifetime of the site.



Fibrelite's Gilbarc/China EL-GC-T05403-SH10 dispenser sumps

## Long Working Life - Tried and Tested Reliable Performance

Fibrelite's wide range of dispenser sumps offer a great alternative to polyethylene sumps. The strong rigid structure will not deflect under groundwater pressure. The simple two piece design provides a large working space to install pipework inside the sump, before the top section is installed.



Vacuum tested tank sumps

## Highly Effective in Preventing Water Ingress

Many areas have persistently high water tables and Fibrelite's vacuum testable tank sumps have proved highly effective in preventing water ingress and subsequent damage to tank top equipment and possible water contamination to the fuel.

Fibrelite Supply Tank Sumps and Manhole Covers to NIS Gazprom Neft in Romania



Grand opening of NIS Gazprom Neft's new Petrol station in Romania

Fibrelite's lightweight, watertight manhole covers and tank sumps have been specified by Gazprom in Romania



Gazprom have specified Fibrelite's fully conductive 1.6m dia chambers (S16) to facilitate easy maintenance post installation

## Highly Effective in Preventing Water Ingress

Many areas have persistently high water tables and Fibrelite's vacuum testable tank sumps have proved highly effective in preventing water ingress and subsequent damage to tank top equipment and possible water contamination to the fuel.

## Long Working Life - Tried and Tested Reliable Performance

Fibrelite's wide range of dispenser sumps offer a great alternative to polyethylene sumps. The strong rigid structure will not deflect under groundwater pressure. The simple two piece design provides a large working space to install pipework inside the sump, before the top section is installed.



Fibrelite's FL100/CD cover. The central dip cover makes it easy to access the riser without having to remove the whole cover

## Industry Leading Composite Covers

Fibrelite's industry leading 25 and 40 tonne rated covers are used on fuel stations all over the world in the toughest of conditions. Watertight and easily removable - they are the preferred choice of oil companies worldwide.





*The GRP chambers are fully adjustable to accommodate shallow tank burial depths*



*Fibrelite's tank sump with central dip internal lid*

With a global reputation for high quality products and superior after sales support, Fibrelite supply to over 70 countries worldwide and consistently produce products that can deliver in the toughest on-site conditions.



*Newly designed 1.7m (S17) diameter tank sumps being installed in Norway*

Fibrelite has manufactured their largest tank sump to date (1.7m dia.) to encapsulate the double manway lid configuration on storage tanks manufactured by CGH Nordic.

Fibrelite distributors Asennusliike Lahtinen OY and Engell & Kristiansen are the first customers for the new tank sump supplying UNO-X and ABC in their local markets.

Fibrelite's vacuum testable fibreglass tank sumps and 25 ton rated GRP composite covers are being installed in both Norway and Finland.

### Testable and Watertight

Fibrelite's high-technology RTM production methods are used to create a range of high quality fibreglass equipment which is both testable and watertight.

### Testable Containment, Consistent Structural Integrity

Fibrelite's high quality one-piece moulded tank sumps have a smooth finish for easy handling during installation. Designed and manufactured to withstand high groundwater pressure after installation for the lifetime of the site.

### Industry Leading Composite Covers

Fibrelite's industry leading 25 and 40 tonne rated covers are used on fuel stations all over the world in the toughest of conditions. Watertight and easily removable - they are the preferred choice of oil companies worldwide.



*Fibrelite's latest tank sump design installed on CGH Nordic storage tanks*



# Petrol Forecourt and Green Area, Thailand



## Fibrelite Supply Watertight Tank Sumps and Manhole Covers for the Petrol Forecourt and Green Area in Thailand

### Now Allowing Easy and Safe Access

Fibrelite's lightweight, watertight manhole covers and tank sumps have been specified by a leading oil company in Thailand.

Fibrelite's access covers are lightweight, durable and very strong. Every Fibrelite cover is manufactured using high-technology RTM production methods to create a highly engineered, monolithic composite product.



Thailand Petrol Forecourt and Green Area



Fibrelite's watertight covers and tank sumps



40" (1020mm) Fibrelite cover (FL 100) with 25 tonne load rating

### Highly Effective in Preventing Water Ingress

Many areas have persistently high water tables and Fibrelite's vacuum testable tank sumps have proved highly effective in preventing water ingress and subsequent damage to tank top equipment and possible water contamination to the fuel.

### Lockable, Watertight Tank Sumps

In addition to using lightweight C250 1000mm forecourt covers for trafficked areas, Fibrelite has also supplied lockable, watertight tank sumps for the green area which perfectly fit the clients' requirements.



Fiberglass turbine sump with 55" tank collar



Fiberglass green area turbine sump with lockable watertight lid

# Total Petrol Station, Cape Town, South Africa



Fibrelite Supply Direct Fill Sumps, Tank Sumps and Manhole Covers for a Truck Stop Area in Cape Town, South Africa



No deflection, no cracking, Fibrelite covers will last the life time of the site



Watertight Fibrelite 450mm (18") round covers (FL 180) and lifting aid (FL7A)

## Project Overview

Fibrelite's lightweight, watertight manhole covers, tank sumps and direct fill sumps have been specified by Total in South Africa.

Fibrelite's access covers are lightweight, durable and very strong. Every Fibrelite cover is manufactured using high-technology RTM production methods to create a highly engineered, monolithic composite product.

## Highly Effective in Preventing Fuel Spills When Refuelling

Fibrelite's easy to install, fully testable direct fill sumps can be supplied with or without a fuel drain back to the tank. The primary containment bucket is supplied with an inspection port to view the secondary containment during routine maintenance.

## Industry Leading Composite Covers

Fibrelite's industry leading 25 and 40 tonne rated covers are used on fuel stations all over the world in the toughest of conditions. Watertight and easily removable – they are the preferred choice of oil companies worldwide.



Fibrelite cover installed in truck lane



Fibrelite direct fill spill buckets (without drain back to tank) specified by Total



Now allowing easy and safe access



## Highly Effective in Preventing Water Ingress

Many areas have persistently high water tables and Fibrelite's vacuum testable tank sumps have proved highly effective in preventing water ingress and subsequent damage to tank top equipment and possible water contamination to the fuel.



900mm (36") Fibrelite cover (FL 90) with 40 tonne load rating



Fibrelite cover with easy to remove FL7A lifting aid over a 1.2m (42") watertight turbine sump

# Premier Retail Fuelling Facility, USA



## Premier Retail Petroleum Facility Chooses Fibrelite Tank Sumps and Covers



US premier retail petroleum facility

### Fibrelite's 'Best of the Best' Products Specified

While designing the underground storage tank and piping system for the site, the architects chosen by the Mashantucket Pequots requested that the "best of the best" products be used throughout the system. Fibrelite's local distributor, Wildco, Inc., recommended that the architects specify Fibrelite fill sumps, tank sumps and manhole covers for the tank top area.

### Watertight and Maintenance-Free

Fibrelite recommended the S14CR-3100/MP fill sump system along with its S14CR-3100/WT watertight turbine sumps. Both the fill sump and turbine sump systems are designed to be watertight and maintenance free. The systems include fibreglass tank sumps with watertight lids and manhole covers. The fill sumps use watertight Fibrelite FL100/MP multiports while the turbine sump kits include an FL100 watertight cover.



Fibrelite turbine and fill sumps



Fibrelite structural platforms

The world's largest casino, Foxwoods Resort Casino located in Ledyard, Connecticut on the Mashantucket Pequot Indian Reservation has now completed the development of a premier gasoline station and convenience store located on the casino property.

The new facility is called the Pequot Outpost and includes a Mobil gas station, convenience store and restaurant. The 24-pump gas station provides both gasoline and diesel fuel and is open around the clock.

### Highly Engineered, Monolithic GRP Composite

Fibrelite's 40" watertight multiport direct fill covers and 40" composite covers are lightweight, durable and very strong. The covers include "multi-wiper" gaskets that ensure a watertight seal. Every Fibrelite cover is manufactured using high-technology RTM production methods to create a highly engineered, monolithic GRP composite product. Fibrelite's tank sumps are also designed using high-tech vacuum-assisted moulding production methods and are factory-tested under vacuum to ensure they will be watertight.

### On-Site Support and Vacuum Testing

For the Pequot Outpost job, Wildco supplied a single fill sump and turbine sump system for each of the (4) underground storage tanks. Fibrelite also provided site support and vacuum testing services during the installation and construction process. Each joint of the tank sump was fibreglassed and bonded to ensure a watertight seal. Prior to backfilling the sumps, Fibrelite vacuum tested each of the sumps to ensure that the sump walls and joints were vacuum and watertight.



Tank pad showing FL100-MP Fibrelite multiport cover and FL100 cover



# Caltex Petrol Station, Cape Town, South Africa



Fibrelite Supply Watertight Tank Sumps and Manhole Covers for Caltex in Cape Town, South Africa



Now allowing easy and safe access

Fibrelite's lightweight, watertight manhole covers and tank sumps have been specified by Caltex in South Africa.

Fibrelite's access covers are lightweight, durable and very strong. Every Fibrelite cover is manufactured using high-technology RTM production methods to create a highly engineered, monolithic composite product.



Recently upgraded site with Fibrelite's 900mm covers (FL90's)

## Testable and Watertight

Fibrelite's high-technology RTM production methods are used to create a range of high quality fibreglass equipment which is both testable and watertight.



Watertight Fibrelite covers and tank sumps

## Highly Effective in Preventing Water Ingress

Many areas have persistently high water tables and Fibrelite's vacuum testable tank sumps have proved highly effective in preventing water ingress and subsequent damage to tank top equipment and possible water contamination to the fuel.



Fibreglass 1.2m (42") turbine sump

Fibrelite Supply GRP Tank Sumps, Dispenser Sumps and Covers, Pennsylvania, USA



*New site in Pennsylvania*

## Now Allowing Easy and Safe Access

Fibrelite's vacuum testable GRP tank sumps and 25 ton rated GRP composite covers and multiports have been specified for this site.



*Fibrelite's 42" E85 compatible tank sumps being installed on double wall steel tanks*



*Fibrelite's E85 compatible Encore 500 dispenser sumps*

## Testable Containment, Consistent Structural Integrity

Fibrelite's high quality one-piece GRP tank sumps have a smooth finish for easy handling during installation. Designed and manufactured to withstand high ground water pressure after installation for the lifetime of the site.

## Long Working Life - Tried and Tested Reliable Performance

Fibrelite's wide range of GRP dispenser sumps offers a great alternative to polyethylene sumps. The strong rigid structure will not deflect under groundwater pressure. The simple two-piece design provides a large working space to install pipework inside the sump, before the top section is installed.



*Vacuum testing to ensure a watertight installation*

## Testable and Watertight

Fibrelite's high-technology RTM production methods are used to create a range of high quality GRP equipment which is both testable and watertight.



# WAWA Convenience Retailer, Pennsylvania, USA



Fibrelite Supply Tank Sumps, Multiport Direct Fill Covers, Monitoring Sumps and Covers to WAWA in Pennsylvania, USA



New WAWA site in Pennsylvania

## Now Allowing Easy and Safe Access

Fibrelite's vacuum testable fibreglass tank sumps and 25 ton rated GRP composite covers and multiports have been specified by WAWA in the United States



Fibrelite's 40" (1020mm) sealed multiport direct fill covers and 18" (180mm) monitoring well covers

Fibrelite's 40" (1020mm) sealed multiport direct fill covers and 18" (450mm) monitoring well covers Fibrelite's access covers are lightweight, durable and very strong. Every Fibrelite cover is manufactured using high-technology RTM production methods to create a highly engineered, monolithic GRP composite product.

## Testable and Watertight

Fibrelite's high-technology RTM production methods are used to create a range of high quality fibreglass equipment which is both testable and watertight.

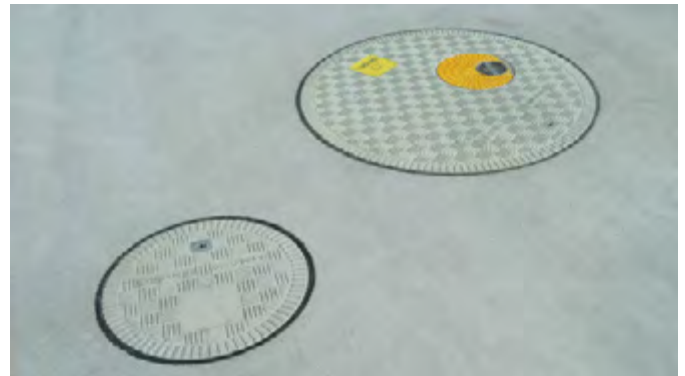

Fibrelite's offset fill port (8" off centre) with colour coded easily removable, watertight fill ports together with an 18" watertight monitoring well cover



Fibrelite's 40" (1020mm) multiport with colour coded easily removable, watertight fill / vapour ports



Easily removable port covers

In addition to using lightweight C250 40" (1020mm) manhole covers for trafficked areas, Fibrelite has also supplied, watertight monitoring well sumps and covers which perfectly fit the clients' requirements.

## Z Energy Oil Company, Auckland, New Zealand



Fibrelite Supply Tank Sumps and Interstitial Monitoring Sumps to Z Energy in Auckland, New Zealand



Recently upgraded site with Fibrelite's 1020mm covers (FL100) and 300mm covers (FL120)

Fibrelite's vacuum testable fibreglass tank sumps and 25 tonne rated composite covers have been specified by Z Energy Oil Company in New Zealand.



Fibrelite's 1020mm sealed cover with easily removable central dip port

### Testable and Watertight

Fibrelite's high-technology RTM production methods are used to create a range of high quality fibreglass equipment which is both testable and watertight.



Fibrelite's tank sump with central dip internal lid

### Testable Containment, Consistent Structural Integrity

Fibrelite's high quality one-piece moulded tank sumps have a smooth finish for easy handling during installation. Designed and manufactured to withstand high groundwater pressure after installation for the lifetime of the site.



Fibrelite's 1.6m 12 sided tank sump with central dip stick

Products were supplied by Fibrelite's distributor Petroleum Equipment Services in Auckland.



# Convenience Retailer, Tokyo, Japan



Fibrelite Supply Tank Sumps, Dispenser Sumps, Transition Sumps and Conduit Drawpits to a Major Convenience Retailer in Tokyo



Site under construction

Fibrelite's vacuum testable fibreglass tank sumps and dispenser sumps have been specified by a major convenience retailer in Japan.

As part of a 'New To Industry' fuel station construction program Fibrelite used its high-technology RTM production methods to create a range of high quality fibreglass equipment for the specialised Japanese market.



Fibrelite's 1.4m 16 sided tank sumps being installed

## Testable Containment, Consistent Structural Integrity

Fibrelite's high quality one-piece moulded tank sumps have a smooth finish for easy handling during installation. Designed and manufactured to withstand high groundwater pressure after installation for the lifetime of the site.

## Long Working Life - Tried and Tested Reliable Performance

Fibrelite's wide range of dispenser sumps offer a great alternative to polyethylene sumps. The strong rigid structure will not deflect under groundwater pressure. The simple two piece design provides a large working space to install pipework inside the sump, before the top section is installed.



Fibrelite's Tokico AB26L dispenser sumps



Fibrelite's vapour recovery transition sumps being vacuum tested to ensure a watertight installation

## Watertight, Vacuum Tested Cable Drawpits

Fibrelite's wide range of cable drawpits give watertight and vapour tight installations which will not deflect under ground water pressure.

## Perfect Watertight Sealing of Cable Penetrations and Pipework

A major issue facing oil companies around the world is leaking pipework and cable penetrations through the chamber wall. Fibrelite's range of pipe and cable entry sealkits provides the perfect watertight solution.



Fibrelite's electrical conduit drawpit being installed

Fibrelite Supply Tank Sumps, Dispenser Sumps, Remote Fill Sumps and Manual Dip Sumps to a Petron Filling Station in Sabah and Sarawak, East Malaysia



Site under construction

Fibrelite's vacuum testable fibreglass tank sumps and dispenser sumps have been specified by a regional oil company in Malaysia.



Fibrelite's 1.2m 16 sided turbine sumps being installed



Fibrelite's locking watertight internal lid supplied with all turbine sumps

## Testable Containment, Consistent Structural Integrity

Fibrelite's high quality one-piece moulded tank sumps have a smooth finish for easy handling during installation. Designed and manufactured to withstand high groundwater pressure after installation for the lifetime of the site.



Fibrelite's Gilbarco Advantage 36 dispenser sumps



Fibrelite's Gilbarco Legacy dispenser sump

## Watertight, Vacuum Tested Cable Drawpits

Fibrelite's wide range of cable drawpits give watertight and vapour tight installations which will not deflect under ground water pressure.

## Factory Assembled and Easy to Install

Fibrelite's remote fill sumps are pre-installed with specified pipework at their Malaysian factory and vacuum tested prior to shipment to site. Secondly contained and fitted with all Viton seals, Fibrelite's wide range of remote fill sumps are suitable for blended fuels.



Cable drawpit with 32mm conduit piping

## Long Working Life - Tried and Tested Reliable Performance

Fibrelite's wide range of dispenser sumps offer a great alternative to polyethylene sumps. The strong rigid structure will not deflect under groundwater pressure. The simple two piece design provides a large working space to install pipework inside the sump, before the top section is installed.



Fibrelite's manual dip and interstitial monitoring sumps being installed



Fibrelite's watertight vacuum tested manual dip sump



## Testable and Watertight

Fibrelite's high-technology RTM production methods are used to create a range of high quality fibreglass equipment which is both testable and watertight.



*Secondarily contained Fibrelite remote fill sumps with anti-slip step down platforms*

# Oil Company, Tokyo, Japan



Fibrelite Supply Tank Sumps, Dispenser Sumps and Double Sided Pipe Entry Boots to Major Oil Company in Tokyo



Site under construction

Fibrelite's vacuum testable fibreglass tank sumps and dispenser sumps have been specified by a leading oil company in Japan. As part of a TCI pipe replacement program Fibrelite used its high-technology RTM production methods to create a range of high quality fibreglass equipment for the specialised Japanese market.



Fibrelite tank sumps and dispenser sumps being installed

## Testable Containment, Consistent Structural Integrity

Fibrelite's high quality one-piece moulded tank sumps have a smooth finish for easy handling during installation. Designed and manufactured to withstand high groundwater pressure after installation for the lifetime of the site.



Vacuum tested tank sumps

## Long Working Life - Tried and Tested Reliable Performance

Fibrelite's wide range of dispenser sumps offer a great alternative to polyethylene sumps. The strong rigid structure will not deflect under groundwater pressure.

The simple two piece design provides a large working space to install pipework inside the sump, before the top section is installed.



Fibrelite's Tatsuno GAB3662 dispenser sump

## Perfect Watertight Sealing of Cable Penetrations and Pipework

A major issue facing oil companies around the world is leaking pipework and cable penetrations through the chamber wall. Fibrelite's range of pipe and cable entry sealkits provides the perfect watertight solution.



Fibrelite's double sided 6" (160 mm) entry boots (Model No: PSBD/ 160)





## COMMERCIAL FUELLING

**OPW** 

**DEFINING** | WHAT'S NEXT

# District Heating, Rennes, France

OPW Provides Bespoke Piping Solution for Leading Heating Network



A demanding district heating redevelopment project in Rennes, France

## Project Overview

A demanding district heating redevelopment project in Rennes, France for an industry leader in the design, construction and operation of specialist heating networks. KPS and Fibrelite products provided the ideal solution including tailor-made KPS fittings.

## Problem

In order to ensure adherence to mandated procedures relating to safety and productivity, essential redevelopment works to 8 x 100,000 litre diesel storage tanks had to be conducted within a tight construction deadline.

Bespoke pipework for existing narrow steel chambers was required. This often poses a problem to pipe suppliers, many of which can only supply standard products. A Fibrelite vent transition sump was also required.



OPW provided a tailor-made KPS piping solution

## Solution

After consulting with both the client and the installer working on this project OPW provided a custom KPS piping solution which would accommodate the existing steel tank chambers. The solution included an integrated double wall termination fitting combined with entry boot (KP TM125/110SC-C) and as requested general arrangement drawings were provided at each stage of design process to the customer.

To provide easy access to the vent stacks the customer specified Fibrelite transition sumps. The bespoke vent transition sumps were a two-vent stack S11-2-VENT which provided a watertight solution.



Fibrelite vent transition sump provided easy access to KPS single wall suction system and double wall suction system (pictured)

## Results

All products were supplied to site within the strict construction deadlines, minimising disruption to the onsite facilities.

KPS piping and Fibrelite dispenser sumps provided a compact long-term solution. KPS piping allowed an excellent ratio between effective diameter of fuel passage and compact external diameter, limiting the required size of the trenches and is electrostatically safe conductive piping provided the highest possible level of safety for the Ethanol's potential to generate charge.





*Fibrelite's long lasting watertight vent transition sumps and KPS conductive piping*



*KPS conductive double wall piping provides the highest possible level of safety for Ethanol's potential to generate charge*

# Fuel Delivery System, Maldives

KPS Provides Easy-Install Safe Fuel Delivery System for Maldives Island's Sole Energy Source



Maldives island's energy is dependent on shipped in fuel

## Project Overview

Like a number of small islands this one is completely dependent on fuel shipped in. This is stored in overground tanks then used to refuel boats and power generators producing energy for the entire island. This island had been recently bought by a Czech entrepreneur, and was relying on antiquated equipment and piping. KPS was approached to provide a reliable long-term solution.

## Problem

When bought, the island was fitted with old obsolete equipment, requiring complete rebuilding including replacing previously installed corroding steel piping and extending and building new jetties.

When a fuel delivery ship arrived at the designated jetty, fuel needed to be transported to the storage facility at the centre of the island (red line on image, approx. 500m away). From here, fuel needed to be distributed to two other jetties to refuel boats (blue line on image, approx. 800m from centre of island). As this was the island's only energy source, a very reliable solution was required. Equipment installed would have constant exposure to saltwater, need to be safe in case of sparks generated when delivering fuel and allow no fuel to permeate into the ground, protecting the scenic local flora and fauna. Due to the large amounts of piping, easy installation was key.



Island overview with fuel delivery jetty (red) fuel storage (box in centre) and refuelling jetty (blue)



Unwrapping the KPS 75/63SCEC double wall fuel coil for the new fuel line



Fuel delivery jetty: piping has constant exposure to saltwater



Installer friendly KPS piping allowed for quick easy installation





*Fuelling lines running from jetty to storage point*



*Refuelling lines running from storage point to jetty*

**Solution**

KPS piping provided a safe easy-install solution requiring the minimum possible number of welds (KPS double wall piping requires less welds than any other system available). Double wall 125/110 conductive pipe carries fuel from the delivery jetty to storage, then double wall 75/63 conductive pipe carries fuel to refuelling jetties.

Piping is installed on hanging mounts below jetties allow an efficient fuelling process. The double wall piping ensures no permeation of fuel into surrounding environment. KPS pipe is completely un-reactive to saltwater, eliminating the risk of deterioration with constant exposure. Conductivity ensures safe grounding in the event of sparks or static electricity generated while fuelling.



*Installed piping from fuelling jetty to storage tanks ready for burial*



*Fuelling lines run below jetty from ship to storage point*



*KPS piping is impervious to corrosion from saltwater*

**Results**

Installation went smoothly and finished on schedule. Now the island and holiday resort have a reliable discreet energy source with no danger to surrounding wildlife.

# Thermal Power Plant, Saint-Pierre, Réunion Island

OPW Products Provide Safe Easy-Install Solution for New Diesel Ethanol Reunion Island Power Plant



The thermal power plant was on a narrow plot stretching lengthwise



KPS Piping and Fibrelite sumps and chambers were installed

## Project Overview

Reunion Island's thermal power plant used a combination of KPS and Fibrelite products to overcome many issues including a tight installation schedule, the complexity of a narrow site and harsh weather conditions.



Multiple contractors were working at once on the Reunion Island site

## Problem

The thermal power plant generator turbine uses Diesel and Ethanol, the switch between these two fuels is quite complex and the process must be followed carefully. The challenge was to use pipes that have low head losses and are compatible with both fuels. Due to Ethanol's potential to generate charge, it requires the highest possible level of safety.

The site is quite narrow (narrow plot stretching lengthwise) and the different contractors: civil construction, piping, turbine installers, and similar needed to work as quickly as possible to avoid blocking the site and slowing the build schedule. Réunion Island is also prone to hurricane and tropical heavy rains, meaning the sumps needed to be completely liquid tight.



OPW provided a compact solution combining KPS piping and Fibrelite sumps

## Solution

KPS piping ensured a compact solution, allowing an excellent ratio between effective diameter of fuel passage and compact external diameter, limiting the required size of the trenches. KPS' electrostatically safe conductive piping was used to provide the highest possible level of safety for the Ethanol's potential to generate charge.

The installer friendly fittings (KPS double wall fittings require less welds than any other system) saved a substantial amount of time during installation, whilst Fibrelite's vacuum tested sumps proved the perfect solution as the only truly liquid-tight solutions available. A full training session was performed on site by a KPS / Fibrelite certified trainer in order to ensure a high quality installation.

## Results

OPW provided a compact solution combining KPS piping and Fibrelite sumps, which fit perfectly in the narrow site configuration within a tight timeframe, including a full certified onsite training session ensuring a high-quality installation.





## COVERS FOR PRECAST TRENCHES

**FIBRELITE** 

**WE'VE GOT YOU COVERED**



## Fibrelite and Trenwa Provide Lightweight Road Crossing Trench Covers for Leading US Utility Provider



Custom HS20 Fibrelite covers in Trenwa's precast concrete trenches



Trenwa's precast trenches ready for installation

### Project Overview

Substations have large amounts of electrical conduits and cabling which are usually run underground in precast concrete or cast in place trenches. Precast trenches are frequently preferred for their ease of installation and consistent fabrication. Fibrelite and Trenwa have a strategic partnership, offering joint products incorporating Fibrelite's composite covers installed on Trenwa's precast trenches.

This leading US utility company chose Trenwa and Fibrelite's HS20 road crossing trenches for their new electrical substation.



Fibrelite and Trenwa's partnership product offering: light strong access covers inset into heavy duty trenches

### Problem

Historically precast concrete trenches have been covered with concrete or metal covers. Where high load ratings are required (like road crossings), such covers can weigh many hundreds of pounds and are therefore difficult to remove and replace. In addition, over time environmental factors can cause metal covers to corrode and concrete covers to crack, fracture or crumble.



Fibrelite offers custom branding and colors

### Solution

Working with Trenwa, Fibrelite developed a line of lightweight composite covers specifically to fit Trenwa's precast concrete road crossing trenches and designed to handle HS20 (40,000lb / 20 ton) load ratings. The Fibrelite trench covers are extremely durable, non-conductive, chemically resistant and not adversely affected by extreme weather or environmental conditions. The covers are also light enough to be safely and easily removed by two operators when monitoring or maintenance of the conduits or cables in the trench is required.





## Results

Fibrelite covers will withstand traffic and harsh field conditions for many years. When combined with Trenwa's precast road crossing trenches, they create an ergonomic yet affordable system for drive over areas, currently available for trenches from 10" to 48" wide.

*Fibrelite trench covers have an anti-skid surface allowing for safe walking or driving in all conditions*

# Renewable Energy Power Station, UK

Cutting Edge Composite Trench Covers for Cutting Edge Renewable Energy Power Station

**FIBRELITE** 

**StantonBonna**



Garreg Lwyd wind farm under construction

## Project Overview

Under the EU's renewable energy plan (still in place post-Brexit) the UK set targets to meet 15% of their energy needs from renewable sources by 2020, including generating 30% of electricity from wind, solar and other low carbon sources (The Guardian, 2016). Wales selected 7 SSAs (Strategic Search Areas) in Wales chosen for good wind speeds and lack of statutory designations. One of these was selected as a site for Garreg Lwyd large scale wind farm, which will be capable of providing sufficient renewable electricity to meet the average needs of more than 26,000 homes.

The project consists of 17 turbines, a control building and a substation to supply power to the grid at the correct voltage and amperage. Substations require large amounts of cabling and other utilities set below the ground while being easily accessible.

When considering materials and products to use when building this power station of the future, they specified future materials and products that will endure into it.

## Requirement

At the substation, there are two long pre-cast concrete trenches: one 19 metres long with a span of 765 mm, the other 25 metres long with a span of 1250 mm. The trenches are set flush into the ground, with an edging created using upright concrete slabs. The trenches required a covering solution that could be easily manually removed for maintenance and monitoring, while performing at D400 load rating (40 tonne). The Sub-station specified a GRP composite solution to meet the required specifications. Covers also needed to provide a safe walking surface for operators, whatever the weather conditions.

Stanton Bonna, the pre-cast trench manufacturer partnered with Fibrelite to create a series of custom GRP trench covers to fit onto their pre cast concrete trenches.



Covers 'stepped' to reduce weight and fit trench width

## Results

Fibrelite covers are a fit-and-forget solution: no maintenance is required, and the composite material has an inherent resistance to corrosion. Structural performance is guaranteed for years to come, with all covers independently tested to BS EN124 criteria.

Lifting and manual handling issues are eliminated. All Fibrelite GRP trench covers are safely removable by two operators, even at D400 (or F900!). This means increased efficiency on site when performing essential maintenance, while preventing risk of injury or need for specialised heavy lifting equipment.



The standard Fibrelite tread pattern provided the perfect slip resistance required for a safe walking surface



Bespoke Fibrelite trench covers 1250mm span





25 metre long precast concrete trench with 1250mm span



Fibrelite covers are a fit-and-forget solution: no maintenance is required



Fibrelite D400 trench covers on wind farm substation



The wind farm will be capable of providing renewable electricity to meet the average needs of more than 26,000 homes

## Solution

Fibrelite designed and manufactured a series of custom GRP trench covers to fit onto the Stanton Bonna pre-cast concrete trenches. Covers are 'stepped' to reduce unit weight and increase the load rating capability. The D400 load rated 1250 mm wide covers can be safely manually removed by two operators without risk of injury. The equivalent size concrete panel would have weighed approx. 400Kg. The standard Fibrelite tread pattern provided the perfect slip resistance required for a safe walking surface, with test reports demonstrating that even when wet, Fibrelite covers have anti-slip properties far exceeding health and safety advisory limits.



*Covers safely manually removed with Fibrelite's ergonomically designed lifting handles*



*Slit trench with stepped covers over electrical cabling*



## Substation Rebuild, USA

### Fibrelite Trench Covers Chosen for High Profile Substation Rebuild After Hurricane Sandy Destruction



*Fibrelite trench covers can withstand heavy loads*

#### Fibrelite Trench Covers Can Withstand Heavy Loads

Fibrelite's HS-20 load rated composite trench covers have been selected by one of the nation's largest metropolitan electrical utilities for a high profile rebuild of a 345 kV bulk power substation. The substation is located in a low-lying coastal area that was subjected to severe flooding caused by Hurricane Sandy in 2012. The substation was flooded due to the hurricane's strong winds and subsequent storm causing significant damage to critical power transmission equipment and forcing the utility to take it offline during the storm.

As part of the utilities' efforts to protect its substations and generating facilities from future storms and hurricane damage, many of the transformers, switches and control equipment at the site were raised above the 100-year flood level elevation. As part of this process, the utility installed several hundred linear feet of concrete trench to run new cabling and underground circuits. The utility chose to install HS-20 load rated road crossing concrete trench manufactured by Trenwa, Inc., one of North America's largest and best known manufacturers of pre-cast concrete trench. Trenwa's concrete trench was equipped with Fibrelite composite trench covers that can carry heavy vehicle loads while being light enough to be easily removed and replaced by hand.

#### Fibrelite's Composite Access Covers and Trench Covers – Tested and Proven Results

The load bearing capacity of Fibrelite's composite trench covers was tested during the rebuilding of the electrical substation. Mobile crane trucks were driven onto the site in order to assist with the installation of new transformer towers and a moat wall around the perimeter of the facility. These mobile crane trucks are designed to lift up to 50 tons and the trucks alone weigh nearly 80,000 lbs. When the crane trucks crossed over the trench section, the axle load transmitted to the 36" wide covers is approximately 26,400 lbs. Fibrelite's unique trench cover design can handle these extreme axle loads without any complications.

#### Trenwa Trenches and Fibrelite Covers

In 2015, Fibrelite and Trenwa jointly released a new line of Fibrelite composite trench covers designed specifically for Trenwa's pre-cast concrete road crossing trench (HS-20).

The Fibrelite trench covers are non-conductive, chemically resistant, lightweight yet extremely durable and will withstand heavy traffic loading and harsh field conditions for many years. When combined with Trenwa's concrete road bases they create an ergonomic, yet affordable system for drive-over areas. They are available for all of Trenwa's road crossing trench products from 10" wide to 48" wide.



*HS-20 load rated trench covers are strong enough to handle an 18 tonne load*

### Fibrelite's Trench Covers Specified for a Brand New Restaurant Opening at London Zoo

Fibrelite's heavy duty composite trench covers have been specified for expansion work at London Zoo. The newly installed D400 trench panels are lightweight while maintaining the all-important strength properties of a 40 tonne load rated cover.

The trench covers provide easy and safe access to the ducting below and are regularly driven over by heavy goods vehicles. Designed as a 'fit and forget' product, the maintenance free Fibrelite trench panel is perfect to cover large areas that require frequent or occasional access.

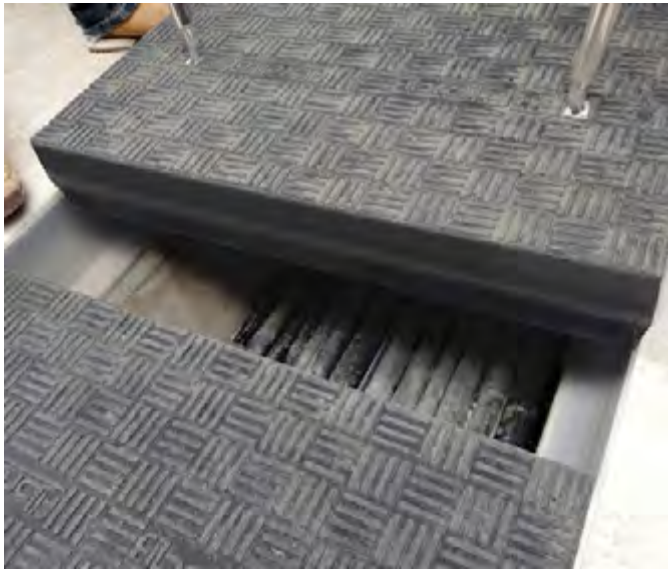

*For ease of installation and to provide a better seating face, a specially designed aluminium frame can be provided*

#### The Versatile Trench Cover

With ranging widths, depths and lengths available together with the option of coloured covers and logos Fibrelite trench covers are extremely versatile. All covers are BS EN 124 load rated, from A15 (1.5 tonne, pedestrian traffic) to E600 (60 tonne). Suitable for an extremely broad range of applications including water treatment plants, stadia, hospitals, airports, ports, dockyards, retail and industrial developments.

Fibrelite can provide to any requirement you may have, supplying the truly versatile trench cover



*Fibrelite's trench covers available in various depths, widths and sizes*

#### Summary of Composite Benefits Versus Steel and Concrete

- Improved health and safety, safe manual handling
- Improved efficiency and productivity
- Airtight and watertight
- Corrosion resistant
- Resistant to aggressive chemicals
- No resale value to the scrap market so will not be stolen
- Non-metallic and will not spark
- Composite is lightweight, strong and unlike concrete will not crumble or crack



*Fibrelite's ergonomically designed lifting handle make for easy and safe removal and entry to the ducting below*



## Fibrelite Supply D400 Trench Covers for the Construction of New Trenches at a Pharmaceutical Plant in Cumbria



*From an initial website search for lightweight composite panels to the installation of 190 new Fibrelite covers*

This is for extensive new construction work to redirect pipework from overhead gantries to underground. The site is regularly trafficked by heavy goods vehicles, which is why D400 covers were critical. Also the company are actively involved in health and safety and could see the huge potential of lightweight covers for easy and quick removal. Various sizes have been manufactured to cater for the corners and smaller sections so a perfect fit is achieved.

The construction involved pre-cast concrete trenches with a concrete rebate for the covers to be housed into. Extremely strong and easy to maintain with no maintenance issues was of great benefit to the customer.

During the installation, the Fibrelite technical team worked closely with the engineers and contractors from the design stage of the panels to delivery ensuring that the product was of the highest specification and the products were installed within the required project time frames.

### Sophisticated Highly Specialised Material

Fibrelite is the world leading manufacturer of Glass Reinforced Plastic (GRP) composite manhole covers and trench covers. This sophisticated and highly specialised material is fast becoming recognised as the more effective modern alternative to traditional materials such as heavy steel and concrete.

Benefits over the more traditional, technologically inferior metal covers:

- Lightweight for easy and safe manual removal
- Load ratings from A15 to F900 (BS EN 124)
- Chemically inert and corrosion resistant

### No Compromise on Performance

Upon request, Fibrelite can provide bespoke and custom solutions. This means that the panel dimensions, internal stiffeners and fibre architecture can be altered to optimise the performance of each panel based on project specific design criteria.

### Benefits of Fitting a Fibrelite

- Customised solutions
- A fit and forget product that will not corrode or fade
- Improved productivity for maintenance crews
- Improved health and safety practices
- Technical support



*The senior designer on site commented that everyone was very pleased with the finished result*

## World Class Biopharmaceutical Manufacturer Continues to Specify Fibrelite for Multi-Million Pound Redevelopment



*Newly fitted pedestrian traffic trench with anti-slip resistance as standard*

### Project Overview

Having supplied a retrofit solution to a previous service trench that was trafficked by HGV's the customer approached Fibrelite to design a bespoke trench cover for this pedestrian traffic trench.

### Solution

Fibrelite manufactured, supplied and fitted approx. 195 metres of bespoke trench covers within a very tight build programme working alongside the principle contractor. The covers had to be designed to accommodate directional changes in the existing trench without any additional support being fitted. As part of the trench covering system was used to extend over a pedestrian cross-over, it was also essential that the covers complied with the appropriate skid/slip resistant requirements which come on all Fibrelite covers as standard.



*Custom designed and manufactured Fibrelite covers to fit in existing trench*

### Problem

The existing trench covers were of very low quality and could not sustain loading from pedestrian traffic. As the boundary wall was being re-located exposing the trench covers to potential pedestrian traffic, it was essential that the replacement covers were designed to withstand a loading of 1.5 tonne (A15).



*Previously installed low quality concrete covers*



*Concrete covers unable to withstand pedestrian traffic*





*Lightweight composite trench covers*



*Maintenance free easy to remove Fibrelite covers installed*

## **Results**

The installation of the trench covers was completed and delivered within the very tight build programme working alongside the Principle Contractor. The GRP covers provide a chemically inert, maintenance free and easy to remove covering solution.









## POWER STATIONS & SUBSTATIONS

**FIBRELITE** 

**WE'VE GOT YOU COVERED**



## UK Power Station Adopts Made-to-Measure D400 GRP Access Covers for 5 Road Crossing Trenches



Bespoke lightweight Fibrelite covers and frames installed at UK power station

### Project Overview

Electrical power generation facilities have large quantities of cabling running below the ground as a matter of course, which must be accessed regularly. Back in the 1960s when many of these facilities were built, heavy concrete and steel or cast-iron trench access covers were the only option available.

At this facility, previously installed concrete infill covers were deteriorating, exacerbating manual handling risks and running the potential of restricting vehicular access to certain areas of the site.

Fibrelite designed and engineered custom GRP D400 load rated access covers to fit existing apertures, alleviating manual handling risks for today and years to come.



Previously installed concrete infill covers had deteriorated, making covers dangerous to remove, even with specialist personnel and equipment

### Problem

The previously installed heavy concrete infill covers had always been difficult to remove due to their weight, but the deterioration of the covers (pictured above) exacerbated the issue, causing a major hindrance to staff when access was required to the services within the trench. The deterioration also compromised the structural integrity of the covers, potentially restricting vehicular access to the site where trenches ran across road crossings.

Some of the key issues cited by the client:

- Deep cracks had formed within the concrete covers which had led to them fracturing entirely in some areas
- Covers dangerous to remove and replace even with specialist personnel and equipment
- Vital maintenance to trench services had to be delayed
- Fractured concrete a trip hazard and eyesore
- Fragmentation was amplified by the regular heavy vehicular traffic loads

The dilapidation of the covers eventually became too disruptive to ignore, and a safe long-term solution was required.



Deep cracks had formed in the corroded previously installed covers



Corroded previously installed cover hinge



## Solution

Fibrelite was approached for a solution through IJM, a customer with which they had worked on a large number of similar projects over many years.

Fibrelite worked with IJM to create five sets of lightweight made-to-measure GRP composite access covers and accompanying aluminium frame sections.

Key features for this project:

- Covers and frames were designed to fit existing apertures, minimising installation cost and time
- Lightweight and strong – the D400 load rated (equivalent to 11t single slow-moving wheel load) covers can be safely manually removed by two people using the FL7 ergonomically designed lifting handle, alleviating manual handling issues (Fibrelite D400 covers are available up to a 1600mm span)
- Inherent resistance to corrosion, requiring a minimum of maintenance while providing a long-term solution
- Securing system to prevent unauthorised access (an optional extra offered by Fibrelite)

The delivery schedule was discussed and guaranteed months in advance as is the usual procedure for this customer. All products were manufactured and supplied within a month of receiving a purchase order from the client.



*Fibrelite access covers have an inherent resistance to corrosion*



*Fibrelite covers and frames were designed to fit existing apertures*



*D400 load rated covers can be safely removed by two people*

## Results

*'As ever I am always striving for excellence and to date have been more than satisfied with Fibrelite's products and the personal service they give me.'*

**Ian Marsh – IJM Director**



Garreg Lwyd wind farm under construction

### Project Overview

Under the EU's renewable energy plan (still in place post-Brexit) the UK set targets to meet 15% of their energy needs from renewable sources by 2020, including generating 30% of electricity from wind, solar and other low carbon sources (The Guardian, 2016). Wales selected 7 SSAs (Strategic Search Areas) in Wales chosen for good wind speeds and lack of statutory designations. One of these was selected as a site for Garreg Lwyd large scale wind farm, which will be capable of providing sufficient renewable electricity to meet the average needs of more than 26,000 homes.

The project consists of 17 turbines, a control building and a substation to supply power to the grid at the correct voltage and amperage. Substations require large amounts of cabling and other utilities set below the ground while being easily accessible.

When considering materials and products to use when building this power station of the future, they specified future materials and products that will endure into it.

### Requirement

At the substation, there are two long pre-cast concrete trenches: one 19 metres long with a span of 765 mm, the other 25 metres long with a span of 1250 mm. The trenches are set flush into the ground, with an edging created using upright concrete slabs. The trenches required a covering solution that could be easily manually removed for maintenance and monitoring, while performing at D400 load rating (40 tonne). The Sub-station specified a GRP composite solution to meet the required specifications. Covers also needed to provide a safe walking surface for operators, whatever the weather conditions.

Stanton Bonna, the pre-cast trench manufacturer partnered with Fibrelite to create a series of custom GRP trench covers to fit onto their pre cast concrete trenches.



Covers 'stepped' to reduce weight and fit trench width

### Results

Fibrelite covers are a fit-and-forget solution: no maintenance is required, and the composite material has an inherent resistance to corrosion. Structural performance is guaranteed for years to come, with all covers independently tested to BS EN124 criteria.

Lifting and manual handling issues are eliminated. All Fibrelite GRP trench covers are safely removable by two operators, even at D400 (or F900!). This means increased efficiency on site when performing essential maintenance, while preventing risk of injury or need for specialised heavy lifting equipment.



The standard Fibrelite tread pattern provided the perfect slip resistance required for a safe walking surface



Bespoke Fibrelite trench covers 1250mm span





25 metre long precast concrete trench with 1250mm span



Fibrelite covers are a fit-and-forget solution: no maintenance is required



Fibrelite D400 trench covers on wind farm substation



The wind farm will be capable of providing renewable electricity to meet the average needs of more than 26,000 homes

## Solution

Fibrelite designed and manufactured a series of custom GRP trench covers to fit onto the Stanton Bonna pre-cast concrete trenches. Covers are 'stepped' to reduce unit weight and increase the load rating capability. The D400 load rated 1250 mm wide covers can be safely manually removed by two operators without risk of injury. The equivalent size concrete panel would have weighed approx. 400Kg. The standard Fibrelite tread pattern provided the perfect slip resistance required for a safe walking surface, with test reports demonstrating that even when wet, Fibrelite covers have anti-slip properties far exceeding health and safety advisory limits.



*Covers safely manually removed with Fibrelite's ergonomically designed lifting handles*



*Slit trench with stepped covers over electrical cabling*



## Substation Rebuild, USA

Fibrelite Trench Covers Chosen for High Profile Substation Rebuild After Hurricane Sandy Destruction



*Fibrelite trench covers can withstand heavy loads*

### Fibrelite Trench Covers Can Withstand Heavy Loads

Fibrelite's HS-20 load rated composite trench covers have been selected by one of the nation's largest metropolitan electrical utilities for a high profile rebuild of a 345 kV bulk power substation. The substation is located in a low-lying coastal area that was subjected to severe flooding caused by Hurricane Sandy in 2012. The substation was flooded due to the hurricane's strong winds and subsequent storm causing significant damage to critical power transmission equipment and forcing the utility to take it offline during the storm.

As part of the utilities' efforts to protect its substations and generating facilities from future storms and hurricane damage, many of the transformers, switches and control equipment at the site were raised above the 100-year flood level elevation. As part of this process, the utility installed several hundred linear feet of concrete trench to run new cabling and underground circuits. The utility chose to install HS-20 load rated road crossing concrete trench manufactured by Trenwa, Inc., one of North America's largest and best known manufacturers of pre-cast concrete trench. Trenwa's concrete trench was equipped with Fibrelite composite trench covers that can carry heavy vehicle loads while being light enough to be easily removed and replaced by hand.

### Fibrelite's Composite Access Covers and Trench Covers – Tested and Proven Results

The load bearing capacity of Fibrelite's composite trench covers was tested during the rebuilding of the electrical substation. Mobile crane trucks were driven onto the site in order to assist with the installation of new transformer towers and a moat wall around the perimeter of the facility. These mobile crane trucks are designed to lift up to 50 tons and the trucks alone weigh nearly 80,000 lbs. When the crane trucks crossed over the trench section, the axle load transmitted to the 36" wide covers is approximately 26,400 lbs. Fibrelite's unique trench cover design can handle these extreme axle loads without any complications.

### Trenwa Trenches and Fibrelite Covers

In 2015, Fibrelite and Trenwa jointly released a new line of Fibrelite composite trench covers designed specifically for Trenwa's pre-cast concrete road crossing trench (HS-20).

The Fibrelite trench covers are non-conductive, chemically resistant, lightweight yet extremely durable and will withstand heavy traffic loading and harsh field conditions for many years. When combined with Trenwa's concrete road bases they create an ergonomic, yet affordable system for drive-over areas. They are available for all of Trenwa's road crossing trench products from 10" wide to 48" wide.



*HS-20 load rated trench covers are strong enough to handle an 18 tonne load*



## Cadent Gas Continues to Specify Custom Fibrelite Trench Access Covers to Simplify Access and Increase H&S



*Fibrelite covers continue to be installed at Cadent Gas facilities across the UK*

### Project Overview

Cadent Gas continue to roll out bespoke Fibrelite GRP composite trench access covers to their facilities across the UK to replace failing concrete infill covers, simplify access and increase H&S.



*Previously installed covers had begun to degrade/rust*



*Previously installed concrete infill access covers were causing problems for facilities, especially when it was necessary to gain access to the services beneath*

### Problem

Previously installed concrete infill access covers were causing problems for facilities, especially when it was necessary to gain access to the services beneath.

#### Key issues:

- Weight – the heavy concrete/metal covers were extremely difficult to remove and replace, requiring calling out of specialist machinery and/or personnel in order to gain access to trench services
- Degradation/corrosion – covers had begun to degrade/rust during their service

A simple safe solution was needed that would also prevent unauthorised removal of the covers.



## Solution

The Fibrelite technical team designed custom GRP composite trench access covers to fit each aperture, supplied product drawings to Cadent Gas to approve, then manufactured and supplied covers to sites within six weeks from receipt of orders.

Some key features for these projects:

- Lightweight – Fibrelite's B125 load rated covers are approximately a third of the weight of the previously installed concrete/metal covers
- Easy, safe two-person manual removal using Fibrelite's ergonomically designed FL7 lifting handles
- Bespoke 101.6mm high grade aluminium cover frame sections designed to accommodate existing rebates, minimising upheaval to sites
- Security – covers manufactured with restraining bolts incorporated preventing unauthorised access
- Chemically inert composition – 'Fit and forget' covers will last for years to come without the need for maintenance



*Fibrelite's GRP composite covers have a chemically inert composition and will last for years to come without the need for maintenance*

## Results

Cadent Gas is discussing rolling out Fibrelite covers to a number of further UK sites in the near future.

Fibrelite and Trenwa Provide Lightweight Road Crossing Trench Covers for Leading US Utility Provider



Custom HS20 Fibrelite covers in Trenwa's precast concrete trenches



Trenwa's precast trenches ready for installation

Project Overview

Substations have large amounts of electrical conduits and cabling which are usually run underground in precast concrete or cast in place trenches. Precast trenches are frequently preferred for their ease of installation and consistent fabrication. Fibrelite and Trenwa have a strategic partnership, offering joint products incorporating Fibrelite's composite covers installed on Trenwa's precast trenches.

This leading US utility company chose Trenwa and Fibrelite's HS20 road crossing trenches for their new electrical substation.

Problem

Historically precast concrete trenches have been covered with concrete or metal covers. Where high load ratings are required (like road crossings), such covers can weigh many hundreds of pounds and are therefore difficult to remove and replace. In addition, over time environmental factors can cause metal covers to corrode and concrete covers to crack, fracture or crumble.



Fibrelite offers custom branding and colors

Solution

Working with Trenwa, Fibrelite developed a line of lightweight composite covers specifically to fit Trenwa's precast concrete road crossing trenches and designed to handle HS20 (40,000lb / 20 ton) load ratings. The Fibrelite trench covers are extremely durable, non-conductive, chemically resistant and not adversely affected by extreme weather or environmental conditions. The covers are also light enough to be safely and easily removed by two operators when monitoring or maintenance of the conduits or cables in the trench is required.



Fibrelite and Trenwa's partnership product offering: light strong access covers inset into heavy duty trenches





## Results

Fibrelite covers will withstand traffic and harsh field conditions for many years. When combined with Trenwa's precast road crossing trenches, they create an ergonomic yet affordable system for drive over areas, currently available for trenches from 10" to 48" wide.

*Fibrelite trench covers have an anti-skid surface allowing for safe walking or driving in all conditions*

# Electrical Substation, Sheffield, UK



## Sheffield Substation Upgrades to Made-to-Measure Fibrelite Trench Covers to Alleviate H&S Risks



Bespoke Fibrelite GRP composite covers installed at electrical substation in Sheffield

### Project Overview

Failing concrete trench access covers at an electrical substation in Sheffield were causing severe operating difficulties for onsite staff. Fibrelite and IJM supplied a lightweight bespoke GRP replacement, alleviating operating difficulties.

### Problem

The previous covering arrangement which had been in place on site was a deteriorating, outdated one composed largely of concrete.

The key issues with the previously installed covers were:

- Weight – the concrete access covers were extremely heavy to lift, posing significant health and safety risks to onsite staff
- Deterioration – covers were chipped on the edges, a number of small cracks had formed during service, and they no longer performed well under heavy loads.



The previously installed covering arrangement was deteriorating



Previously installed heavy concrete covers posed significant health and safety risks



Covers were extremely heavy to lift



## Solution

IJM, the company in charge of the project, has worked with Fibrelite on a large number of similar previous projects over many years and so approached Fibrelite for a solution for this facility.

Fibrelite designed and engineered a set of bespoke GRP composite trench covers and aluminium frames. Key features for this project:

- Lightweight and strong: the new D400 load rated covers can be safely and quickly removed and replaced manually by two people using Fibrelite's FL7 lifting handles
- Custom sizing – Fibrelite's adjustable tooling allows them to provide bespoke covers and frames, meaning minimum upheaval incurred to site
- Secure bolt-down design – preventing unauthorised access
- Chemically inert – all Fibrelite covers are made from a highly-engineered composite material that will last for years to come with minimal maintenance

The design and delivery details were agreed a few months in advance, enabling a three-week turnaround from order to delivery.



*Fibrelite's chemically inert covers provide a long-term maintenance-free solution*

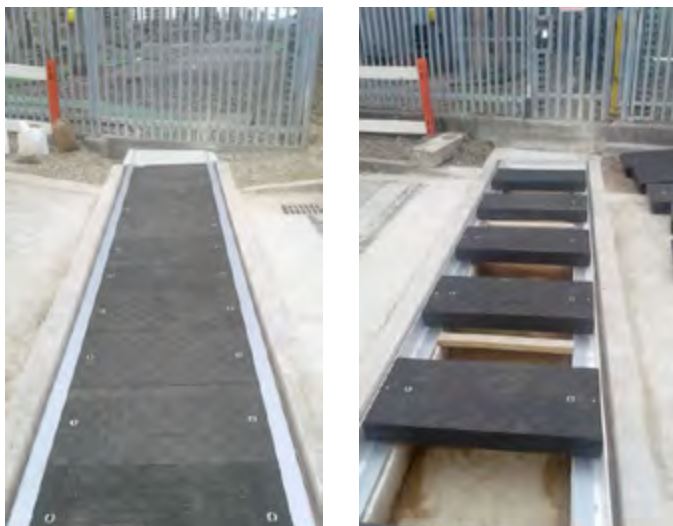

*Fibrelite covers and frames were custom made to fit existing apertures, minimising installation time / upheaval to site*

## Results

Thanks to Fibrelite, the customer now reaps the benefits of a modern, GRP composite trench covering solution including:

- Easy safe access to trench services using the ergonomically designed Fibrelite FL7 lifting handles
- Health and safety risks alleviated



*The new D400 load rated covers can be safely removed by two people*

## Cadent Gas Continue to Specify Fibrelite Bespoke Trench Covers for Their AGI Upgrade Programme



Cadent Gas Valve Pits, North West England



A custom covering solution was required to fit existing apertures and accommodate piping entering trench

### Project Overview

Cadent Gas continue to update their facilities in the North West of England with bespoke Fibrelite access covers again featuring in their development. Fibrelite is fast becoming a distinctive feature of these redeveloped above ground installations (AGIs) throughout the country. In this installation Fibrelite catered to the following unique requirements:

- Custom cover cut-outs to accommodate existing valve networks extending from within the trench to above ground networks
- Redevelopment of rebate – Fibrelite supplied a custom made 50mm deep frame section, allowing the existing rebate to be redeveloped whilst leaving the general arrangement of the access pits undisturbed

### Problem

This project was part of a much larger programme of site redevelopment being carried out in the North West of England. Given the success Fibrelite had with previous installations for this client, they were specified again for this site.

### Key Requirements

- Custom cover sizes to fit existing apertures and piping entering trenches
- More efficient trench access than previously installed concrete covers allowed
- A modern, aesthetically pleasing finish
- Easy to remove covers: The previously installed concrete covers were very heavy and difficult to manoeuvre even though they were only trafficked by pedestrians
- A regimented delivery schedule



Fibrelite supplied a custom made rebate

### Solution

Fibrelite custom designed and engineered bespoke trench covers and frame sections. These were delivered in accordance with the client's regimented delivery schedule.

### Key Properties

- Fibrelite's technical team attended the site before and after installation with Cadent Gas to programme in the necessary works and ensure the successful installation of the trench covers and frame section
- A 50mm deep frame section was designed to accommodate the existing rebate, resulting in a much faster and easier installation process, reducing disruption to site
- Covers were custom cut to accommodate existing valve networks
- Covers can be easily, quickly and safely removed using Fibrelite's FL7 lifting handles



## Results

Fibrelite's bespoke trench covers and frames proved to be the perfect solution. The client achieved the modern, aesthetically pleasing finish they desired as well as greatly increasing their efficiency while reducing health and safety risks to employees and monitoring teams.



*Fibrelite custom designed and engineered bespoke trench covers and frame sections*



*Covers were custom cut to accommodate existing valve network*



*Covers can be easily, quickly and safely removed using Fibrelite's FL7 lifting handles*



Lindley Oil Refinery, Killingholme, UK



Fibrelite covers have resistance to extremely high temperatures and so can withstand the emissions from the steam pipes below them

### Project Overview

A complex large-scale renovation project necessitating a carefully planned bespoke design.



The scale and requirements of this project necessitated a carefully planned bespoke design



Custom sized covers were required to fit the unusual shape of the trench

### Problem

A project like this – in which everything is designed and built from scratch, comes with unique challenges. These were compounded by the tight timeline.

### Key Trench Covers Requirements:

- Load ratings varying from A15 to D400 to cope with differing traffic loads, from pedestrian to heavy vehicular (lorries and loading vehicles)
- Custom sizes to accommodate the unusual shape of the trench
- Resistance to extremely high temperatures to withstand emissions from steam pipes
- Chemically inert – covers must not react/decompose upon contact with the corrosive chemicals associated with crude oil refinery
- Easy safe manual removal



The Fibrelite technical team and engineering team adapt their approach to suit each client and project





*Fibrelite covers are chemically inert*



*Fibrelite covers allow easy safe manual removal*



*Covers were manufactured in load ratings from A15 to D400*



*The skid resistant surface of Fibrelite covers removed the potential risk that would have been posed by concrete covers during periods of adverse weather or oil/chemical spillages*

## Solution

The Fibrelite technical team and engineering team adapt their approach to suit each client and project.

- Custom Fibrelite trench covers were designed and engineered to fit the unusual trench dimensions. Their bespoke design allowed for the covers to be slotted into the existing rebate acting as an immediate and effective covering solution
- The Fibrelite site team were instrumental to the installation, visiting at critical stages during the installation
- Fibrelite adhered stringently to the delivery deadlines as outlined by the client – all 114 covers were manufactured and delivered to site within 4–5 weeks from confirmation of the order. Previously, Fibrelite supplied phase 1 of this project with similar superior speed and efficiency – exceeding client deadline and product quality demands
- Thanks to a swift delivery schedule, the time period in which the steam pipes within the trench were exposed to the harmful elements above was negligible
- Fibrelite covers are maintenance-free and have an inherent resistance to corrosion, meaning they will endure for years to come, even with exposure to the corrosive chemicals associated with crude oil refinery
- The skid resistant surface of Fibrelite covers removed the potential risk that would have been posed by concrete covers during periods of adverse weather or oil/chemical spillages



*The Fibrelite team adapt their approach to suit each client and project*

## Results

- The onsite staff benefit greatly with easy safe manual access to the service trench using Fibrelite's ergonomically designed FL7 lifting handles
- Fibrelite covers remain cool to touch even when subjected to the extreme temperatures from the steam pipes below (tested to temperatures of 200°C)
- 'Fit and forget' – Fibrelite's chemically inert covers will last for years to come without cracking or decomposing with exposure to the range of chemicals they will face in service

## Fibrelite Provide Cadent Gas with Improved Lightweight Composite Alternative for Previously Installed Concrete Trench Covers



Fibrelite's "fit and forget" retrofit replacement for previously installed eroding concrete covers

### Project Overview

Fibrelite was approached by Cadent Gas to provide a long-lasting trench cover solution, which would alleviate some onsite issues associated with previously installed concrete covers at Winwick Road, Warrington. The key issues were:

- Unsafe manual handling
- Slow/inefficient access to valve pits
- Health and safety concerns – heavy, cumbersome covers

As Fibrelite offers the very best strength-to-weight ratio available in the market today, we were the obvious choice for this project.



Fibrelite offers the very best strength-to-weight ratio available in the market today

### Problem

Previously, the removal and replacement of concrete trench covers was very time-consuming due to their sheer weight. The covers were extremely difficult to remove and replace safely, causing manual handling risks for operators.

For this project, the client required a heavy-duty covering solution which wouldn't disturb the existing rebate. This creates an issue for some suppliers who would be unable to produce a custom cut design precise enough to accommodate this.



Previously installed covers were extremely difficult to remove and replace safely

### Solution

The bespoke D400 composite trench covers were manufactured and delivered directly to the site within two weeks from order confirmation, keeping in line with the construction programme. The trench covers were designed as a retrofit solution to the previously installed arrangement to meet the exact requirements of the customer. This included manufacturing at a variety of different depths and load ratings.

Manual handling risks were completely eliminated due to the thermoset plastic composition of Fibrelite covers, meaning that even at a heavy-duty load rating, the covers can be quickly and safely removed by two people using the ergonomically designed FL7 lifting handle.

In addition, the maintenance-free design of Fibrelite's covers requires no specialist lifting machinery during service. Fibrelite trench covers are skid-resistant meaning that previous health and safety concerns have been dramatically reduced especially during periods of adverse weather conditions.



## Results

Post installation, onsite staff at Cadent Gas have benefitted greatly from the 'fit and forget' solution which had been provided. Fibrelite's long-lasting chemically inert covers will not contribute to the erosion of any components within the trench over time and can easily be manually removed by two people using Fibrelite FL7 lifting handle and so time is no longer wasted when conducting necessary work within the trench, as was previously the case during removal/replacement of cumbersome covers.



*Fibrelite manufactured trench covers which were lightweight and maintenance free*



*Easy and safe access to underground systems*

The health and safety issues associated with tired, cracked and crumbling concrete and bowed rusting steel covers have been instantly removed. All these hazards are eliminated with Fibrelite's non-corrosive, non-cracking, slip resistant and incredibly strong trench panels.



*Fibrelite trench covers can be safely and easily manually removed using the FL7 lifting aids*

### How to Eliminate the Hazards - Install Fibrelite Trench Access Covers

For this installation, Fibrelite supplied B125 trench access covers to allow ease of access to a large valve pit (clear opening of 2.25m x 1.2m).

### Summary of Composite Benefits Versus Steel and Concrete:

- Composite is lightweight, strong and unlike concrete will not crumble or crack
- Specially designed lifting aid eliminates back injury and crushed fingers
- Perfect metal theft deterrent as zero re-sale value
- Composite is lightweight, strong and unlike concrete will not crumble or crack
- Non-metallic, non-conductive and will not spark
- Excellent insulator against heat
- Unaffected by underground gasses and most chemicals
- Incredibly strong monolithic structure that will not delaminate
- Treads incorporate a specialised anti-slip material equivalent to modern high grade road surface
- Range of UV stable colours available that will not flake or crack

Designed as a 'fit and forget' product for civil engineering situations. The maintenance free FM45 is perfect for covering large areas, gullies, trenches and ducts where occasional or frequent access may be required.

Panels can be installed on a pre-laid concrete rebate or our modular aluminium frame system which is self-keying into surrounding concrete. They can be used for a multitude of applications: from shopping centre walkways and industrial facilities to HGV loading areas in water treatment plants, utility and power stations. No other covering system matches its easy lift, skid resistance or load carrying properties.

Trench covers are a standard width of 450mm with a range of length options from 800mm to 1600mm. For larger areas of structural flooring, additional central support beams can be installed to extend the covering area. Bespoke sizes are also available - please contact us for further details.



## Substation, Chickerwell, UK

Fibrelite Supply Heavy Duty 800mm Trench Access Covers to Electricity Substation

**FIBRELITE** 



*Fibrelite D400 tonne load rated lightweight trench covers*

### Damaged Cast Iron and Concrete Covers

Extremely heavy and damaged cast iron and concrete covers installed at the Substation caused a health and safety issue and needed replacing. Fibrelite's lightweight heavy duty composite trench covers were specified as the ideal solution. Designed as a 'fit and forget' product, the maintenance free trench covers provide easy and safe access to the electricity cables housed in the trench situated across the road.



*Previously installed corroded and damaged cast iron and concrete covers*



*The previously installed cast iron frame showing signs of damage and corrosion*

### Large Spans at a Heavy Duty Load Rating and a Cost Effective Solution



*Fibrelite's trench covers are non-metallic, non-conductive and will not spark*

This particular project required 800mm long trench covers which met the BS EN 124 D400 load rating. Fibrelite D400 load rated trench covers span from 800mm to 1600mm, meaning large span coverage can be achieved saving the customer time and money.



*The Fibrelite lifting handles are specifically designed for operator use at the optimum ergonomic lifting range*

### Further Advantages Include:

- Lightweight reducing lifting and handling issues: The covers are easily removed by a two man lift, even at D400 load rating
- Improved efficiency and productivity: Quick removal and no expensive lifting apparatus required, just the ergonomically designed Fibrelite lifting handles
- Corrosion resistant
- Composite has no resale value to the scrap market so covers will not be stolen
- Non-metallic and will not spark
- Composite is lightweight, strong and unlike concrete will not crumble or crack
- Guaranteed structural performance: All covers are tested to BS EN 124 D400 load rating



*Fibrelite supply trench access covers to a power station*



*Corroded and deformed cheap steel covers*

### Stage One - Out With the Old

This UK power station removed old fashioned concrete and steel covers that were now severely damaged and replaced them with Fibrelite's lightweight Trench Access Covers. Previously, a forklift and lifting equipment had to be used every time one of the old covers needed to be removed, a costly and time consuming exercise. Now a single person can easily and safely remove the Fibrelite covers, a refreshingly simple and inexpensive task.

As you can clearly see from the images, the tired, cracked and crumbling concrete and bowed rusting steel covers have not only seen better days, but are causing on site health and safety issues. All these hazards are to be eliminated with our non-corrosive, non-cracking, slip resistant and incredibly strong composite trench panels.



*Damaged and difficult to remove: heavy concrete slabs*



## Stage Two - Installation of Fibrelite's Composite Trench Access Covers

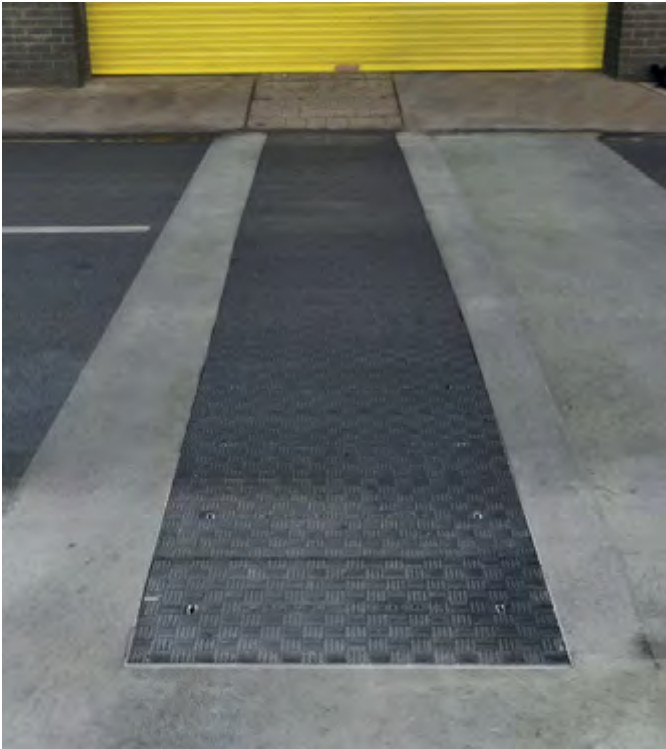

*Fibrelite heavy load rated composite trench cover*

Fibrelite has supplied 7.2m of 1m long trench access covers (D400 load rating). This is for installation in to the road leading to a forklift loading area and where ash removal HGV's are frequently loaded.

**Customer quote:** "We were looking for an installation to replace our ageing duct covers. Fibrelite came up with this solution and it is manufactured and sourced locally."



*Extremely strong and incredibly lightweight covers*

### Summary of Composite Benefits Versus Steel and Concrete:

- Composite is lightweight, strong and unlike concrete will not crumble or crack
- Specially designed lifting aid eliminates back injury and crushed fingers
- Non metallic, non-conductive and will not spark
- Excellent insulator against heat
- Unaffected by underground gasses and most chemicals
- Incredibly strong monolithic structure that will not delaminate
- Treads incorporate a specialised anti-slip material equivalent to modern high grade road surface
- Range of UV stable colours available that will not flake or crack



*Large Span: Fibrelite trench covers go up to 1600mm in length at D400 (40 tonne) load rating*



*Fibrelite can match to any RAL colour*

The second phase installation has been completed as Fibrelite supply 7.65m of 1350mm long trench access covers in D400 load rating. Covers have now been installed in the entrance of the boiler room where HGV's are frequently entering and exiting through the roller doors. The critical requirement was that the covers could withstand the imposed loading from the HGV's.

This particular client required the covers to match the already coloured floor and Fibrelite was able to match exactly to the pale green colour.



*Once removed the concrete covers would never sit back in the frame correctly*



*The previously installed old corroding and crumbling concrete covers*

### Coloured Trench Covers

An important requirement for the customer was that the trench covers matched the surrounding area. All Fibrelite trench and access covers have the option to be supplied in a wide variety of colours, the pigment is introduced directly into the resin during the moulding process, ensuring that the colouring is not merely applied to the surface but evenly and completely infused throughout the cover. No maintenance is therefore required after install. Further customisation can be provided in the form of a logo, making the Fibrelite access cover truly versatile.

This UK Power Station removed crumbling and damaged concrete covers that were severely damaged and replaced them with Fibrelite's lightweight trench access covers. Previously, a forklift and lifting equipment had to be used every time one of the old covers needed to be removed, a costly and time consuming exercise. Now two people can easily and safely remove the Fibrelite covers.

As shown in the images below the tired, cracked and crumbling concrete covers had not only seen better days, but caused on site health and safety issues. All these hazards are eliminated with Fibrelite non-corrosive, non-cracking, slip resistant and incredibly strong composite covers.

### Benefits Overview:

- Lightweight reducing lifting and handling issues: The covers are easily removed by a two man lift, even at heavy duty load ratings
- Improved efficiency and productivity: Quick removal and no expensive lifting apparatus required, just the ergonomically designed Fibrelite lifting handle
- Corrosion resistant
- No resale value to the scrap market so will not be stolen
- Non-metallic and will not spark
- Composite is lightweight, strong and unlike concrete will not crumble or crack
- Guaranteed structural performance: All covers are tested to BS EN 124 standards



## Substation, Germany

### Fibrelite Trench Covers Installed Over Cable Chamber in German Substation

Fibrelite trench covers have replaced integrated steel and concrete panel providing protective covering for a cable chamber at a German substation.

The facility employs maintenance operatives who need to regularly lift the trench covers in order to make checks and repairs to the cabling. However the previously installed covers weren't easy to open because each one weighed around 200 kg!



*The original steel and concrete covers with a depth of 17cm*

### The Maintenance-Free Solution

Fibrelite's composite covers are available in a wide range of sizes, colours and load ratings.

They are maintenance-free, durable and very strong as a matter of course.

### The Composite Solution

Although the client had to make some adjustments to the existing rebate, Fibrelite's GRP composite, light-duty trench covers proved to have a number of advantages over traditional materials. Firstly, the covers are lightweight – typically a third of the weight of an equivalent-size metal or concrete cover – and can be lifted by workers using the Fibrelite specialist lifting handles instead of specialist lifting equipment.

In addition, the ergonomically designed lifting handle has the added benefit of eliminating the risk of back injury and crushed fingers for operatives.

An anti-slip finish is an additional safety benefit with non-slip treads moulded into the product at the manufacturing stage making Fibrelite covers a safer alternative to concrete or metal whatever the weather conditions.



*Fibrelite trench panels installed over the chamber*

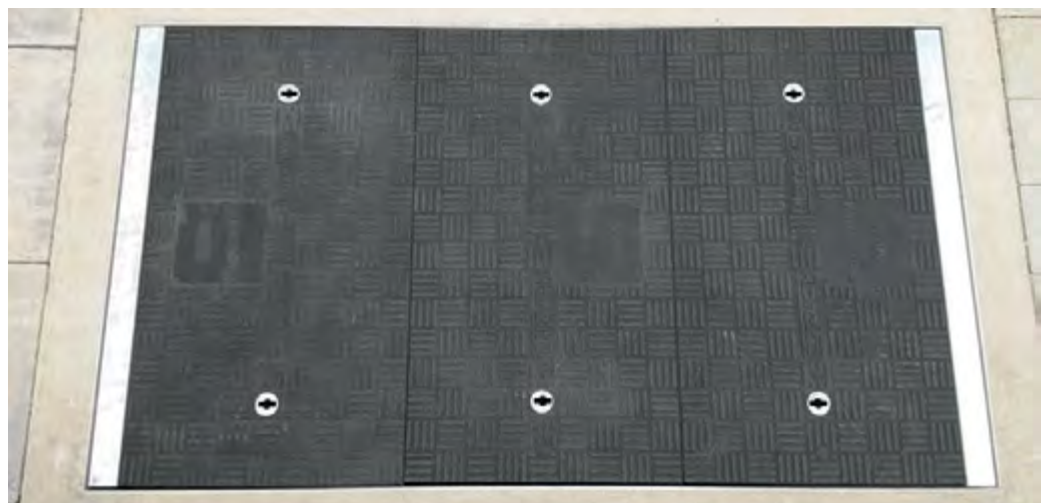

*Covers can be moulded with custom logos*



*Fibrelite B125 (12.5 tonne) load rated lightweight trench and access covers*

Fibrelite's range of covers offer easy access for operators at this Natural Gas processing site. Due to the nature of what is underground the covers need to be easy access for operators who regularly check and monitor the valves and pipework. For operators working at the plant security and manual handling are critical issues when gaining access.

A number of the chambers required covers to be profiled in order to fit around pipework. This is an area of expertise that the Fibrelite site team can offer for bespoke applications. Fibrelite worked closely with both the client and contractor to ensure an extremely tight deadline was met.

Fibrelite's access covers are lightweight, durable and very strong. Every Fibrelite cover is manufactured using high technology Resin Transfer Moulded production methods to create a highly engineered, monolithic composite product.

### Damaged Cast Iron and Concrete Covers Replaced

The previously installed, heavy and damaged cast iron and concrete covers caused a health and safety issue and needed replacing. Fibrelite's lightweight heavy duty composite trench cover was identified as the solution. Designed as a 'fit and forget' product, the maintenance free covers provide easy and safe access to the gas pipework and valves.

### Sophisticated Highly Specialised Material

Fibrelite is the world leading manufacturer of glass reinforced plastic (GRP) composite manhole covers and trench covers. This sophisticated and highly specialised material is fast becoming recognised as the more effective modern alternative to traditional materials such as heavy steel and concrete.

Benefits over the more traditional, technologically inferior metal covers:

- Lightweight for easy and safe manual removal
- Load ratings from A15 to F900 (BS EN 124)
- Chemically inert and corrosion resistant
- Anti-slip / skid properties

### Highly Effective in Preventing Water Ingress

Fibrelite's sealed covers have proved highly effective in preventing water ingress and subsequent damage to essential valve equipment.



*Fibrelite's watertight sealed manhole covers installed*

### No Compromise on Performance

Upon request, Fibrelite can provide bespoke and custom solutions. This means that the panel dimensions, internal stiffeners and fibre architecture can be altered to optimise the performance of each panel based on project specific design criteria.

### Benefits of Fitting a Fibrelite

- Customised solutions
- A fit and forget product that will not corrode or fade
- Improved productivity for both operational and maintenance crews
- Improved health and safety practices
- Technical support





*Corroded and damaged cast iron and concrete covers were replaced with Fibrelite's lightweight trench panels*



*D400 covers installed in an access road on the site*



*Wide range of sizes and colours available*



*Essential cut outs and profiling for the pipework*



*Fibrelite heavy duty trench covers*

Fibrelite's work replacing unsafe and damaged trenches at Substations continues. The existing concrete and cast iron covers had begun to crumble and crack, causing health and safety issues on numerous sites. Trench covers manufactured by Fibrelite do not suffer from such structural issues and are maintenance free.

### Further Advantages include:

- Corrosion resistant
- No resale value to the scrap market so will not be stolen: A thermoset plastic, the composite makeup of the cover means it has no resale value
- Non-metallic and will not spark
- Composite is lightweight, strong and unlike concrete will not crumble or crack
- Guaranteed structural performance: all covers are tested to EN124 D400 load rating
- Colours and logos: available in a vast array of colours and company logos available on request
- Training for the installation team available
- Range of sizes: From 800mm to 1600mm at D400 load rating, increasing in 50mm increments

### Lightweight Covers, Making for Easy Removal and Still Maintaining Heavy Duty Load Rating

Due to their composite make-up, Fibrelite trench covers are lightweight allowing for easy removal even at D400 (40 tonne) load rating. Coupled with the ergonomically designed lifting handle, all previous manual handling concerns and safety risks are no longer an issue. This improves efficiency and productivity on site; making for a quicker, safer and more cost effective working environment.



*Fibrelite composite trench covers and aluminium frame during installation*



*Lightweight composite trench covers*





British Columbia based energy company

A large Canadian developer of geo-exchange heating and cooling projects has decided to use Fibrelite's lightweight composite covers & pots for their thermal energy distribution system. The company utilises a proprietary system for drilling boreholes that allow developers to install geo-exchange energy systems into existing buildings or, while construction of a new building is underway. For purposes of providing convenient access to the distributed piping system, the geoexchange company has chosen to specify Fibrelite's FL180 18" diameter composite access covers due to their superior strength and ease of removal.

Geo-exchange heating and cooling systems are designed to "exchange" heat between a building and the soil located below or around the building. A few feet beneath the Earth's surface, the soil temperature remains fairly constant year round, ranging from 45°F or so in northern latitudes to about 70°F in the south. Geo-exchange takes advantage of these constant soil temperatures to provide extremely efficient heating and cooling.

### Advanced Design – Multiple Applications

Fibrelite is the world leading manufacturer of Fibreglass Reinforced Plastic (GRP) composite manhole covers. This sophisticated and highly specialised material is fast becoming recognized as the more effective modern alternative to traditional materials such as cast iron, steel and concrete.

Though other containment systems and manhole covers had been considered, the following benefits meant Fibrelite's GRP cover and enclosure were chosen for this project:

- Lightweight covers for easy and safe manual removal
- Watertight cover design prevents water infiltration into manhole
- Chemically inert & corrosion resistant
- Will not conduct electricity or heat
- Extremely strong and durable
- Option of personalized logo
- Zero scrap resale value



Fibrelite's 20" diameter enclosures

In the winter, the geo-exchange system circulates a fluid through a network of pipes buried in the ground that absorbs heat from the earth and carries it into the building to be used as heat. In the summer, the process is reversed: heat is extracted from the air in the building and transferred into the earth through the piping. The only external energy needed for the thermal exchange is the small amount of electricity needed to operate the pump or pumps that move the fluid through the piping network.

The connections for the piping network are enclosed within Fibrelite's 20" diameter enclosures installed beneath the Fibrelite FL180 access covers.

The geo-exchange company originally approached Fibrelite with the challenge of manufacturing an 18" diameter cover with a shallow depth that would maintain the load rating capabilities of a standard H20 manhole. Due to Fibrelite's advanced engineering and manufacturing capabilities, we were able to provide the customer with a product that met all of their requirements.



Network of pipes to be buried in the ground

## Gas Valve Plant, UK

Fibrelite's Super Light Duty Trench Covers, the Lightweight Alternative to Heavy Metal Covers



UK gas valve plant

Fibrelite's super light duty trench covers have been selected for an onshore gas valve plant in the UK. The gas valve plant consists of two buildings where Fibrelite's super light duty range of panels (FM45SH-A15) were selected to be installed over a series of cable trenches.

During the installation, Fibrelite's technical team worked closely with the contractor from the design stage of the panels to delivery ensuring that the product was of the highest specification and the products were installed within the required project timeframes.

### Sophisticated Highly Specialised Material

Fibrelite is the world leading manufacturer of Fibreglass Reinforced Plastic (GRP) composite manhole covers and trench panels. This sophisticated and highly specialised material is fast becoming recognised as the more effective modern alternative to traditional materials such as heavy steel and concrete.

Benefits over the more traditional, technologically inferior metal covers:

- Lightweight for easy and safe manual removal
- Non-slip properties equivalent to a high grade road
- Chemically inert and corrosion resistant



Various panel lengths and sizes are fitted

### No Compromise on Performance

Upon request, Fibrelite can provide a semi-custom solution. This means that the panel dimensions, internal stiffeners and fibre architecture can be altered to optimise the performance of each panel based on project specific design criteria.

A clear advantage over cheap and low quality off the shelf products flooding the market.



Easy access using Fibrelite lifting handles





*Special notched panels have been fitted around valves and pipework*



*Longer length trenches with no additional support*



*Non slip coating is applied to the top of the panels*



*Angles and corners can be designed and installed*

## **Benefits of Fitting a Fibrelite**

- Customised solutions
- Fit and forget product that will not corrode or fade
- Improved productivity for maintenance crews
- Improved health and safety practices
- Technical support

# Substation, Dorset, UK



## Fibrelite Replace Heavy Duty Cast Iron and Concrete Trench Covers in a High-Voltage Electrical Substation



Fibrelite's lightweight trench covers

### Helping to Create a Safer and More Efficient Working Environment

The main reasons why Fibrelite covers were specified by for this application:

- Lightweight reduced lifting and handling injuries: the covers can be easily removed with two people using the proprietary lifting handles
- Easy to install: because the covers are lightweight and they are located in a frame the installation is straightforward
- Guaranteed structural performance: all covers for this application were tested to EN 124 D400 load rating
- Range of sizes: 800 – 1600mm spans available with a D400 load rating
- Training for installation team: this is available at the factory

### Range of Lengths Available

Fibrelite's trench access covers are a standard width of 450mm with a range of length options from 800mm to 1600mm. For larger areas of structural flooring, additional central support beams can be installed to extend the covering area.

### Old Installation

Previously installed extremely heavy, corroded and damaged cast iron and concrete covers.



Corroding previously installed covers

Fibrelite's lightweight heavy duty (D400) composite trench covers have recently been specified to replace 10 metres of cast iron and concrete covers. The EN124 D400 tonne load tested lightweight covers are non-metallic, non-conductive and will not spark

The newly installed heavy duty covers now provide safe and easy access to the underground electricity cables which run in a trench across the road. This is the main access road within the substation and is regularly used by heavy goods vehicles.

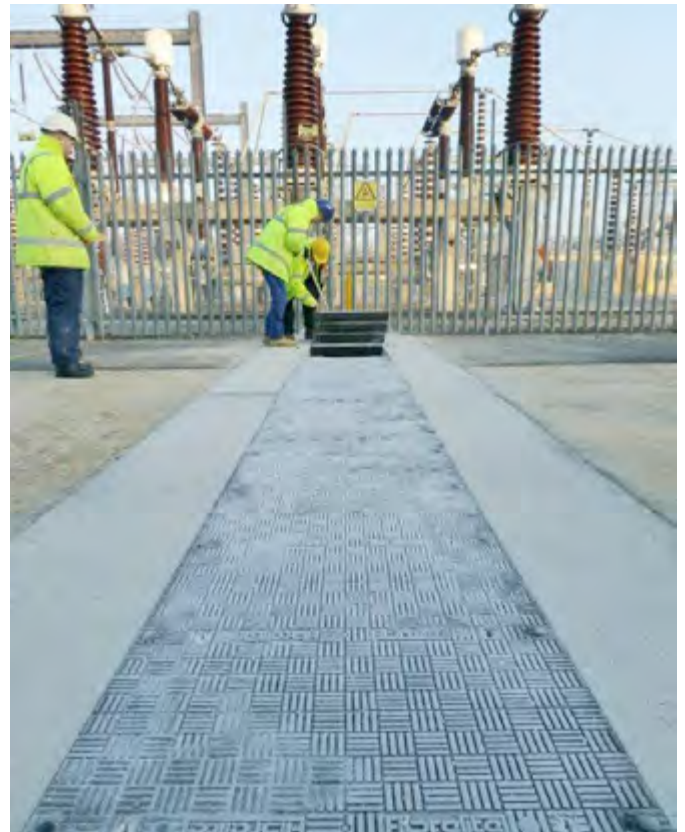

Fibrelite covers provide safe easy access to electrical cabling

### New Installation

Fibrelite conductive D400 load rated trench covers installed on this high voltage electrical substation.



The EN 124 D400 tonne load tested lightweight covers



## Customer Comments

*“IJM Projects Limited is project managing the installation of heavy duty GRP gratings in high voltage electrical substations for the client. During this project it was noted that some road crossings required replacement. A cast iron and concrete replacement was considered because these are still in production but the Fibrelite alternative was chosen as an alternative to trial. Discussions were held at the factory with the design team and alterations were made to suit the client’s requirements and a trial was undertaken. Fibrelite also offered guidance from its own installation team who came to site to meet the installation contractor to generally give advice.*

*Installation was straightforward which was partly due to the lightweight covers and frame. In some installations two trenches run in parallel and now these can be replaced using the 1400 or 1600mm covers rather than two covers and frames. Generally once the covers are installed they very rarely need to be removed but when this is required the Fibrelite covers are very manageable with a two man lift using the proprietary lifting devices.*

*Fibrelite has offices in the UK with technical advice available at all times and working with the designers has ensured that the client has the right product for the application required.”*

Fibrelite Supply Heavy Duty (D400) 1400mm Trench Access Covers to Electricity Substation



*Fibrelite D400 tonne load rated lightweight trench covers*

## Damaged Cast Iron and Concrete Covers Replaced

Extremely heavy and severely damaged cast iron and concrete covers installed at the substation caused a health and safety issue and needed replacing.

Fibrelite's lightweight heavy duty composite trench cover was specified as the solution. Designed as a 'fit and forget' product, the maintenance free trench cover provides easy and safe access to the electricity cables housed in the trench situated across the road.



*Fibrelite's modular frame is guaranteed for 15 years against structural damage*



*Corroded and damaged cast iron and concrete covers*



*The previously installed cast iron frame showing extensive damage and corrosion*



## Large Spans at a Heavy Duty Load Rating Produces a Cost Effective Solution



*Fibrelite composite trench covers*

The original installation used two sets of separate covers over two parallel trenches, but specifying the Fibrelite 1400mm long D400 load rated cover made the installation much easier, reducing installation time and making the install much more economical.

Fibrelite's D400 load rated trench covers span from 800mm to 1600mm, meaning large spans can be achieved saving the customer time and money.



*Covers are non-metallic, non-conductive and will not spark*

### Further Advantages include:

- Lightweight reducing lifting and handling issues: The covers are easily removed by a two man lift, even at D400 load rating
- Improved efficiency and productivity: quick removal and no expensive lifting apparatus required, just the ergonomically designed Fibrelite lifting handle
- Corrosion resistant
- No resale value to the scrap market so will not be stolen: A thermoset plastic, the composite makeup of the cover means it has no resale value
- Non-metallic and will not spark
- Composite is lightweight, strong and unlike concrete will not crumble or crack
- Guaranteed structural performance: All covers are tested to EN124 D400 load rating

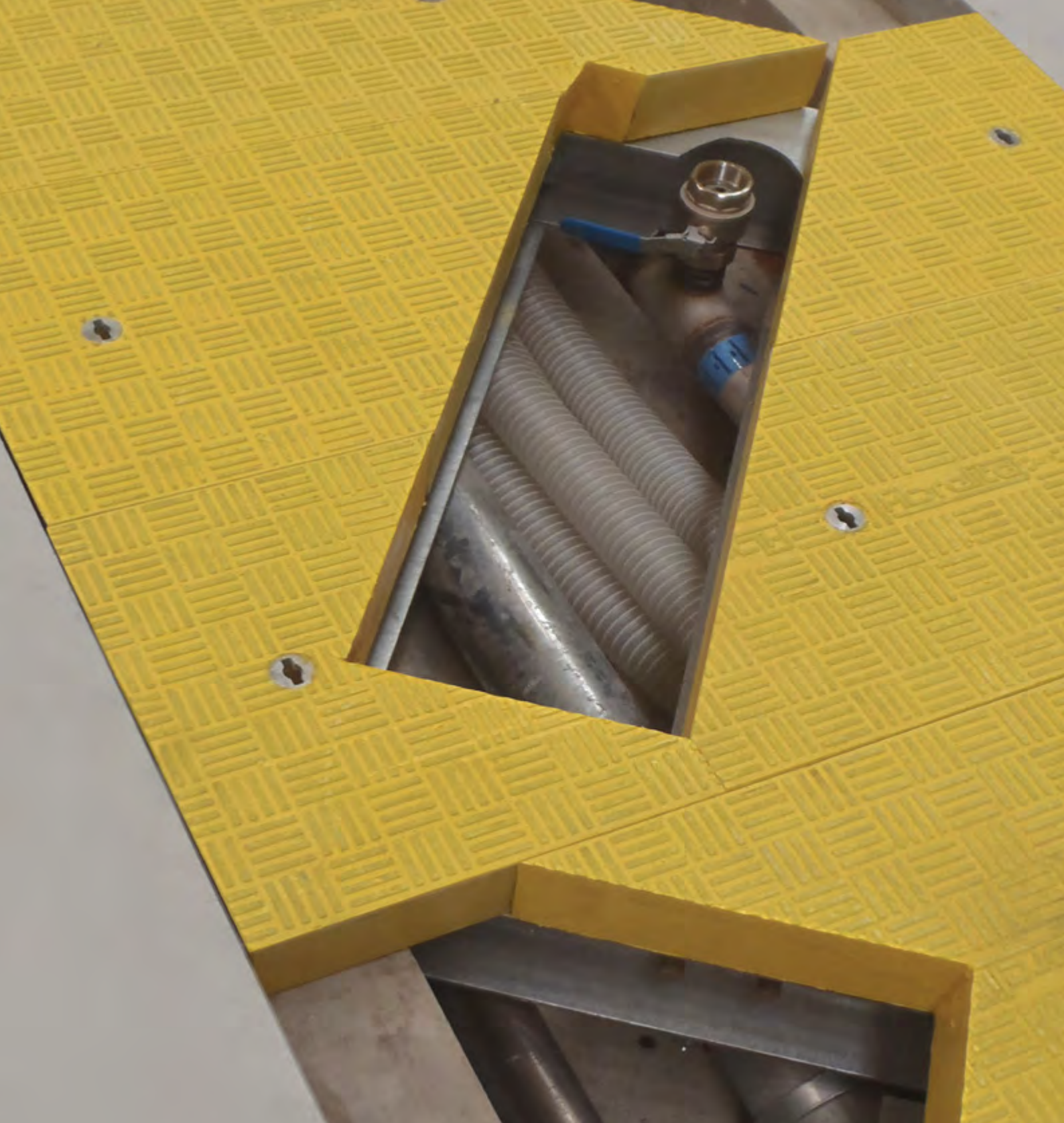





**MANUFACTURING FACILITIES  
& DATA CENTRES**

**FIBRELITE** 

**WE'VE GOT YOU COVERED**





*Bespoke Fibrelite covers provide safe replacement for previously installed concrete covers*

### Project Overview

After a previous successful installation for this end user, BBI (Beacons Business Interiors Ltd) contacted Fibrelite to supply a lightweight retrofit trench covering arrangement to replace previously installed failing concrete covers. Load ratings varied from A15 to D400.

### Problem

The previous installation was a concrete covering arrangement which was presenting a number of problems:

- Covers had cracked and corroded, no longer performing as when installed as well as causing a number of health and safety risks
- Covers were extremely heavy, requiring specialist machinery on site whenever it was necessary to gain access to the service trenches beneath

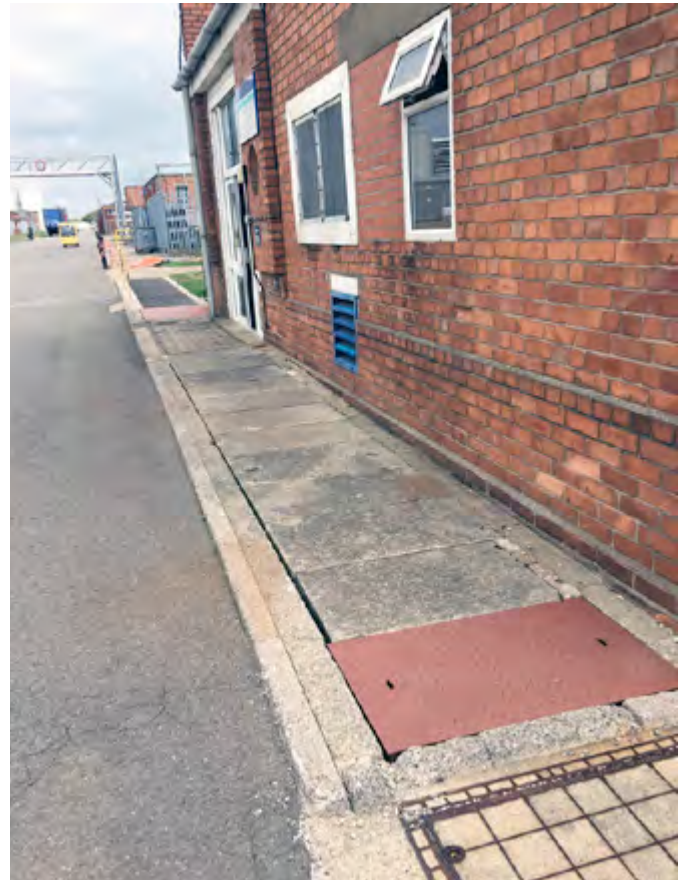

*Previously installed covers had cracked and corroded*



*Previously installed failing concrete trench access covers*



*Covers were extremely heavy, requiring specialist equipment to remove*



## Solution

Shortly after initial contact was made by BBI, the Fibrelite team attended the site to assess the problem and propose the best solution.

The Fibrelite engineering team then created a tailor-made GRP trench access cover solution which included a number of bespoke cover dimensions in various quadrilateral and triangular shapes (below) for terminating trench ends. This minimised disruption of the site, allowing the majority of the covers to be fitted into existing frames.

Covers were manufactured at A15, C250 and D400 load ratings as required. Custom manufactured frame sections at 76mm, 81mm and 101.6mm were also supplied.

Key features of Fibrelite covers for this installation:

- Lightweight, alleviating health and safety risks
- No specialist equipment required to remove or replace – easy two-person manual lift using Fibrelite's ergonomic lifting handles
- 'Fit and forget' – maintenance-free covers will last for years to come
- Aesthetically pleasing



*Fibrelite covers provide a lightweight alternative to concrete, alleviating health and safety risks*



*Fibrelite fit-and-forget maintenance free covers will last for years to come*



*No specialist equipment is required to remove and replace Fibrelite covers – easy two person manual removal*

## Results

Fibrelite delivered the bespoke solution just over 1 month after receiving the order. The customer expressed an interest in updating further UK facilities with Fibrelite trench covers.



*Bespoke Fibrelite GRP composite trench covers*



*The Fibrelite solution included a number of bespoke cover dimensions*



*Aesthetically pleasing finish*

## Hi-Tech Composite Covers for High-Tech Cloud Computing Facility in Hong Kong



Fibrelite trench covers protect fibre optic cabling at emergency vehicle access point (image used for illustration purposes as actual data centre cannot be shown)



Fibrelite covers are designed to withstand heavy loads and harsh weather conditions for many years (Image of a similar installation used for illustration purposes as actual data centre cannot be shown)

### Project Overview

One of the largest data centre developers and operators in Hong Kong S.A.R of China, came to Fibrelite looking for a retrofit replacement for their failing concrete trench access covers. The covers protected and allowed access to fibre optic cables and were located at the entrance of an emergency vehicle access point. A safe reliable replacement was required that would be capable of withstanding heavy vehicle loads and harsh weather conditions including flooding which the area is prone to.

### Problem

The rapid growth of content-heavy mobile applications and cloud computing means that the demand for efficient and secure computer hardware to store data is growing exponentially every year. This facility has many miles of fibre optic cabling along with environment and supply cables in precast concrete cable trenches, which must be protected yet easily accessible and identifiable. Originally, heavy concrete trench covers had been fitted over precast concrete cable trenches.

Due to the weight of the previously installed concrete covers, they had to be small in order for them to be removed and replaced. Despite the size, they were still heavy and challenging to move making the process time consuming, requiring specialised lifting equipment and creating potential health and safety risks. The concrete covers had become damaged over time due to frequent heavy loads and environmental factors, making removal even more difficult while increasing the health and safety risks whilst compromising the protection of the cables.

The client was looking for a simple, long-term custom solution which would enable fast, safe manual removal. The replacement covers needed to be able to withstand a maximum traffic load of 40 tonnes (D400) and harsh weather conditions like flooding, whilst preventing unauthorised access. Minimal replacement time was essential to minimise disruption to the emergency route.

### Solution

Fibrelite designed and manufactured bespoke trench covers to fit directly into the existing frames, making installation quick and easy, minimising disruption to the emergency vehicle access point.

All Fibrelite covers can be safely removed and replaced by two people using the FL7 lifting handles due to their high strength-to-weight ratio. This also enabled less covers to be used in the replacement whilst covering the same aperture. The corrosion-resistant covers can now be removed and replaced safely, minimising disruption and providing a safe walking and driving surface in all weather conditions.

The specified Fibrelite heavy-duty trench covers have a 40-tonne load rating (D400), enabling them to withstand heavy vehicle traffic whilst still being able to outperform concrete on a long-term basis. Designed as a fit and forget product all Fibrelite GRP composite covers are maintenance free corrosion-resistant and ultra-durable.

The covers were fitted with restraining paddles and a unique securing mechanism to prevent unauthorised access and any movement when the area is flooded.

### Results

The client now has a long-term access solution that requires minimal maintenance and will continue to perform year after year, withstanding harsh weather conditions and heavy traffic from emergency vehicles while enabling quick safe access for monitoring and maintenance.

The customer is now considering replacing all the trench covers over the next two to three years.



## Fibrelite Supply D400 Trench Covers for the Construction of New Trenches at a Pharmaceutical Plant in Cumbria



*From an initial website search for lightweight composite panels to the installation of 190 new Fibrelite covers*

This is for extensive new construction work to redirect pipework from overhead gantries to underground. The site is regularly trafficked by heavy goods vehicles, which is why D400 covers were critical. Also the company are actively involved in health and safety and could see the huge potential of lightweight covers for easy and quick removal. Various sizes have been manufactured to cater for the corners and smaller sections so a perfect fit is achieved.

The construction involved pre-cast concrete trenches with a concrete rebate for the covers to be housed into. Extremely strong and easy to maintain with no maintenance issues was of great benefit to the customer.

During the installation, the Fibrelite technical team worked closely with the engineers and contractors from the design stage of the panels to delivery ensuring that the product was of the highest specification and the products were installed within the required project time frames.

### Sophisticated Highly Specialised Material

Fibrelite is the world leading manufacturer of Glass Reinforced Plastic (GRP) composite manhole covers and trench covers. This sophisticated and highly specialised material is fast becoming recognised as the more effective modern alternative to traditional materials such as heavy steel and concrete.

Benefits over the more traditional, technologically inferior metal covers:

- Lightweight for easy and safe manual removal
- Load ratings from A15 to F900 (BS EN 124)
- Chemically inert and corrosion resistant

### No Compromise on Performance

Upon request, Fibrelite can provide bespoke and custom solutions. This means that the panel dimensions, internal stiffeners and fibre architecture can be altered to optimise the performance of each panel based on project specific design criteria.

### Benefits of Fitting a Fibrelite

- Customised solutions
- A fit and forget product that will not corrode or fade
- Improved productivity for maintenance crews
- Improved health and safety practices
- Technical support



*The senior designer on site commented that everyone was very pleased with the finished result*

## World Class Biopharmaceutical Manufacturer Continues to Specify Fibrelite for Multi-Million Pound Redevelopment



*Newly fitted pedestrian traffic trench with anti-slip resistance as standard*

### Project Overview

Having supplied a retrofit solution to a previous service trench that was trafficked by HGV's the customer approached Fibrelite to design a bespoke trench cover for this pedestrian traffic trench.

### Solution

Fibrelite manufactured, supplied and fitted approx. 195 metres of bespoke trench covers within a very tight build programme working alongside the principle contractor. The covers had to be designed to accommodate directional changes in the existing trench without any additional support being fitted. As part of the trench covering system was used to extend over a pedestrian cross-over, it was also essential that the covers complied with the appropriate skid/slip resistant requirements which come on all Fibrelite covers as standard.



*Custom designed and manufactured Fibrelite covers to fit in existing trench*

### Problem

The existing trench covers were of very low quality and could not sustain loading from pedestrian traffic. As the boundary wall was being re-located exposing the trench covers to potential pedestrian traffic, it was essential that the replacement covers were designed to withstand a loading of 1.5 tonne (A15).



*Previously installed low quality concrete covers*



*Concrete covers unable to withstand pedestrian traffic*





*Lightweight composite trench covers*



*Maintenance free easy to remove Fibrelite covers installed*

## **Results**

The installation of the trench covers was completed and delivered within the very tight build programme working alongside the Principle Contractor. The GRP covers provide a chemically inert, maintenance free and easy to remove covering solution.

## Bespoke Fibrelite Covers Accommodate Varying Trench Widths and Pipe and Cable Tray Penetrations at UK Pharmaceutical Facility



Bespoke Fibrelite GRP composite access covers installed at pharmaceutical facility in County Durham



Fibrelite covers are maintenance-free and corrosion resistant

### Project Overview

Fibrelite was approached by McLaughlin & Harvey to design and supply a custom trench access covering solution for a new build project in County Durham to accommodate a variety of trench widths, shapes and pipe and cable tray penetrations, required within a tight build schedule. The client is a high-profile developer of innovative products for the pharmaceutical industry.



Custom Fibrelite trench access covers designed with cut-outs to accommodate piping and cabling



A variety of unique cover shapes were required

### Problem

The client needed a bespoke, tailor made covering solution to cover their variety of trench widths and shapes including accommodation for pipe and cable tray penetrations. Quick easy access to trenches was also required. This project had an extremely tight timeline to minimise disruption to the facility.



Fibrelite covers allow quick easy access to trenches

### Solution

Fibrelite designed and engineered a bespoke GRP composite trench access cover solution with the following key features:

- A variety of unique cover shapes and cut-outs to accommodate trench shapes, depths and pipe and cable tray penetrations
- Lightweight – covers can be safely removed and replaced manually by two people using the FL7 lifting handles
- Maintenance free and corrosion resistant

Covers were manufactured and delivered on site within the tight construction schedule





*Fibrelite's GRP composite trench access covers can be easily and safely manually removed by two people*

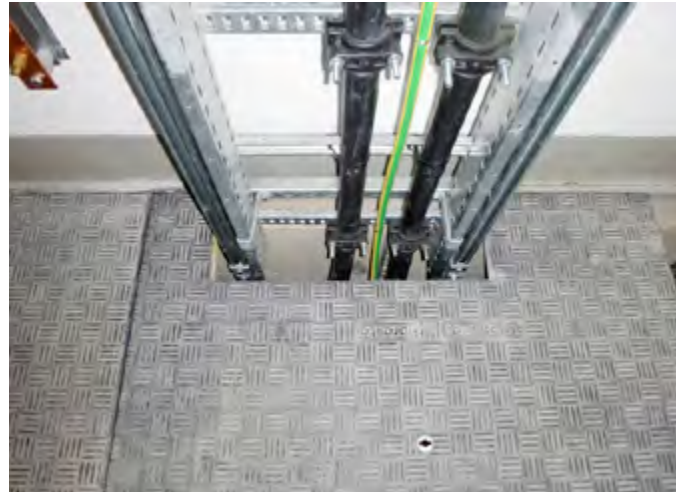

*This project had an extremely tight timeline to minimise disruption to the facility*

## Pharmaceutical Facility Choose Fibrelite GRP Access Covers as a Simple Lightweight Solution



Fibrelite GRP access covers installed at pharmaceutical facility in Northumberland, UK



Heavily corroded previously installed covers

### Project Overview

Officials at a Northumberland pharmaceutical facility came to Fibrelite for a solution to their outdated troublesome access covers, which were situated over trench runs at their pharmaceutical development facility. The performance of Fibrelite's unrivalled strength to weight ratio covers and the client's pursuit of innovative products and solutions were key factors in securing this project as Fibrelite covers are subject to non-standard point loads in excess of 40 tonnes.

### Problem

Accessing the service trench was a time-consuming task which required specialist workers and equipment. The previously installed covers were a mixture of heavy solid concrete units and sheets of metal. The sheets of metal were installed at a later stage to patch over the heavily corroded concrete units. A drill was required for removal and replacement of the initial covers, when removed the concrete covers fragmented and broke apart. The metal sheets had become bent and misshapen especially around the edges and caused a major slip hazard when wet.



Previously installed heavily corroded access covers



Previously installed failing concrete and metal covers



A drill was required for removal and replacement of covers



Sheets of metal had been installed as a temporary patch over failing concrete covers



## Solution

The client required a lightweight, durable solution which offered safe manual handling benefits. Several different parties made contact with us on behalf of the pharmaceutical facility for this project. Tolent Construction were the company tasked with finalising project requirements for the job and helping to progress the enquiry to order stage.

Fibrelite provided bespoke covers that fit directly into the existing frames which can be removed and replaced by two people using the FL7 lifting handles. Because of the heavily trafficked area the customer specified a heavy-duty cover, Fibrelite provided a bespoke E600 load rated cover that is anti-skid, minimising health and safety risks. Designed as a 'Fit and Forget' solution Fibrelite covers are corrosion and maintenance free providing the facility with a long-term solution.



*Fibrelite covers are corrosion and maintenance free*



*Fibrelite lightweight access covers are designed to withstand heavy loads and harsh weather conditions*

## Results

Fibrelite manufactured and delivered the entirety of the order within four weeks from receipt of purchase order, helping to minimise disruption to the facility. It now has a long-lasting access solution that will require minimal maintenance. The customer can now gain access to the service trench without the use of specialist tools. Upon inspection they will find the equipment underneath unspoiled by fragmented bits of cover thanks to the non-corrosive composition of our covers. A purchase order for phase two of this project was placed soon after completion. This would comprise of an even longer service trench than previously installed and in a different area of the facility.

Made-to-Fit Fibrelite Covers Provide Safe Simple Access Solution for the Royal Canadian Mint



Fibrelite covers enable safe easy access to under floor utilities at the Royal Canadian Mint



Underfloor conveyor in trench takes products from presses to packaging

## Project Overview

At the Royal Canadian Mint, conveyor belts and other machinery runs below floor level to conserve space. These require frequent access for monitoring and maintenance. In the search for a safer simpler alternative to previously installed heavy steel panels, they approached Fibrelite.

## Problem

Previously installed heavy diamond plate panels covered under floor conveyor belts and other ancillary equipment within the facility. These were challenging and potentially hazardous for users to remove and replace. Lifting equipment was required, and care had to be taken by users to avoid the large number of pinch points.

Replacement panels were required in load ratings for forklifts (Light Duty - 28,000lbs/B125) and non-forklift areas (Medium Light Duty - 11,200lbs) to fit into existing apertures. Consideration was also given to colours and markings to indicate different facility areas.



Heavy steel diamond plate panels

## Solution

Fibrelite designed and manufactured custom fiber reinforced plastic (FRP) composite trench covers to fit directly into existing apertures. Due to Fibrelite covers' unrivalled strength to weight ratio, all trench covers can be safely and quickly removed by two people using the FL7 lifting handle. This ensures safe lifting from waist height (as recommended by Health and Safety Authorities) eliminating pinch points and potential back injuries.

For forklift areas (Light Duty - 28,000lbs/B125) black FRP covers were manufactured, while for non-forklift areas (Medium Light Duty - 11,200lbs) FRP covers were produced in a custom light gray with a raised no-forklift graphic on top.



Lightweight Fibrelite FRP trench covers allow easy safe manual removal



## Results

The new Fibrelite FRP composite covers can be safely and quickly removed without the need for lifting equipment, eliminating risk of injury and increasing efficiency. Fibrelite covers' anti-slip properties, equivalent to a high grade road surface help to ensure safety of operators in the event of spilled oil or lubricates from machinery sitting on the panels.

Following the success of this installation, the Royal Canadian Mint has decided to install Fibrelite covers in further areas of the facility.

## Testimonial

*“The new FRP composite panels worked out well. Our people are really happy with the way they perform. These lightweight panels do not require strenuous effort to remove and replace and has completely eliminated the risks of employee injuries when performing this task.”*

**Tuan Luong** – Senior Facilities Engineer, Royal Canadian Mint



Custom FRP composite trench covers manufactured to fit into existing rebate



Custom no-forklift graphic and cover colour for non-forklift areas



Leading engine manufacturer, UK

### Project Overview

Manufacturing plants require heavy-duty power cabling into the facilities to power their large amounts of machinery, especially in a highly technical industry like engine manufacture. The cables must be protected, yet easily accessible for inspection. However, existing heavy metal access covers at this facility were allowing water ingress which was affecting the cables.

### Problem

Previously installed leaking steel covers were allowing water ingress, which over time was deteriorating the power cable sheathing. Once deteriorated past a certain point, the cables would have to be replaced to avoid exposing the live wires underneath, causing delays in the facility.

The steel trench covers themselves were also rusting, and very heavy to remove: a time-consuming procedure. The covers were located in an emergency escape route, so it was essential that replacement was conducted as quickly as possible.



Previously installed steel covers over electrical inspection pit



Water ingress due to unsealed covers, causing cable deterioration

### Solution

Fibrelite designed, manufactured and installed a retrofit sealed system, setting an aluminium frame into the existing steel with an epoxy grouting system, preventing the need for breaking out and reinstating the concrete margin. The installation was completed in less than two days, so the walkway was closed for a small amount of time, causing minimal disruptions.

The covers were equipped with a bolt restraining system, so they could be secured, preventing unauthorised access and forming a watertight seal, preventing water ingress.



Retrofitted sealed Fibrelite covers installed



Fibrelite covers are resistant to corrosion and adverse weather conditions



## Results

Fibrelite provided a retrofit watertight solution that was installed in less than two days that will eliminate maintenance issues associated with the previous cover arrangement. Fibrelite covers have an inherent resistance to corrosion and adverse weather conditions; meaning they will continue to perform year after year.

All Fibrelite covers are designed to be manually removed/replaced by either one or two people using the Fibrelite designed lifting handle(s) even at F900 (90 tonne) load rating, meaning that 2 people can now quickly, easily and safely maintain and monitor the power cables.



*Sealed Fibrelite covers prevent water ingress*



*Covers quickly and easily removed by 2 people*



*Secured/restrained covers, preventing unauthorised access*



*Aluminium frame set into existing steel frame with epoxy grout*

Fibrelite Supply Bespoke Trench Covers Over Concrete Trenches That House Essential Pipework and Service Supplies



*The Fibrelite yellow C250 (25 tonne) load rated standard duty trench access covers*



*Essential service pipework required for the production process*

## Fibrelite Supply Trench Covers for Leading UK Aerospace Facility

Fibrelite's range of standard and bespoke covers were designed and manufactured for this complicated application. The main requirement was easy access for operators who regularly need to enter these trenches that supply the manufacturing plant with essential services.

The production areas need to have fully flexible workstations with constant movement of parts and equipment. As new wing assemblies are required the support stations move and therefore the services also move. The panels are lifted regularly to ensure production areas are working efficiently. For operators working within the facility, ease of access and safety are critical.



*Complex corner trench design*

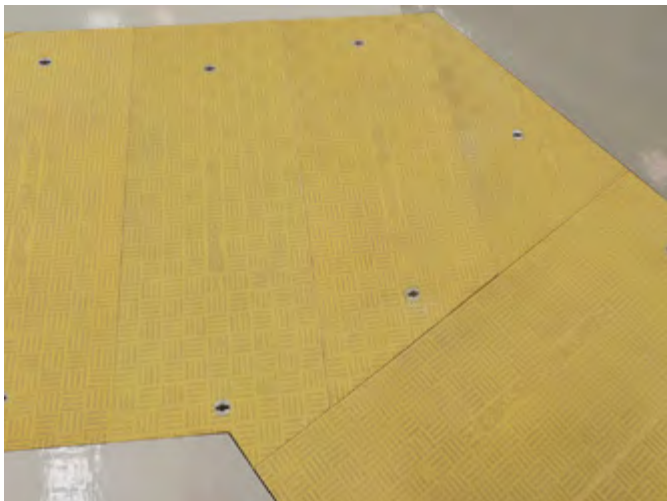

*Bespoke trench covers for complex corner sections*



*Fibrelite covers needed to be manufactured to work with pre-installed steel supports*



Fibrelite's access covers are lightweight, durable and very strong. Every Fibrelite cover is manufactured using high technology resin transfer moulded (RTM) production methods to create a highly engineered, monolithic composite product.

Due to the complexity of this application, the trenches were pre-made with steel support structures in place. For Fibrelite the challenge was to somehow design the trench covers to fit an existing trench that had been designed for an alternative solution.

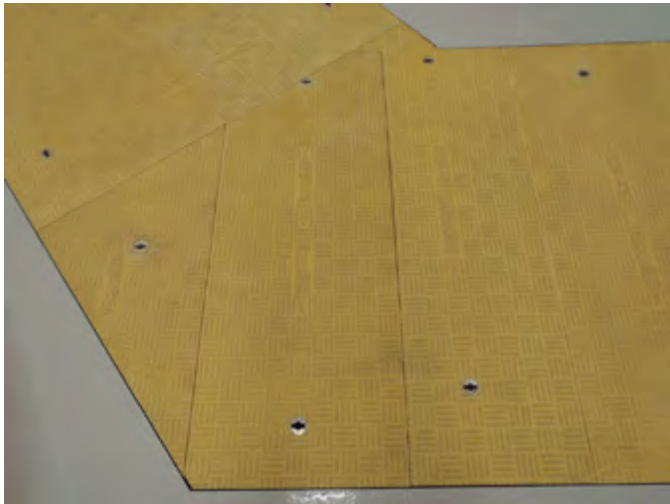

*Chemically inert and corrosion resistant*

Working to an extremely tight deadline and challenging conditions, Fibrelite manufactured a completely bespoke trench panel arrangement. Widths and depths had to be changed and panels cut to exact dimensions to accommodate corner sections and service sections. Fibrelite's lightweight standard duty composite trench cover was identified as the solution. Designed as a 'fit and forget' product, the maintenance free covers provide easy and safe access to the essential pipework.

## Sophisticated Highly Specialised Material

Fibrelite is the world leading manufacturer of glass reinforced plastic (GRP) composite manhole covers and trench covers. This sophisticated and highly specialised material is fast becoming recognised as the more effective modern alternative to traditional materials such as heavy steel and concrete.

Benefits over metal and concrete covers:

- Lightweight for easy and safe manual removal
- Load ratings from A15 to F900 (BS EN 124)
- Chemically inert and corrosion resistant
- Anti-slip/skid properties

## Highly Effective in Preventing Heavy Lifting

Fibrelite's trench covers have proved highly effective in reducing health and safety issues and potential damage to essential pipework.

## No Compromise on Performance

Upon request, Fibrelite can provide bespoke and custom solutions. This means that the panel dimensions, internal stiffeners and fibre architecture can be altered to optimise the performance of each panel based on project specific design criteria.

## Benefits of Fitting a Fibrelite

- Customised solutions
- A fit and forget product that will not corrode or fade
- Improved productivity for both operational and maintenance crews
- Improved health and safety practices
- Technical support

# Paper Factory, Germany



Fibrelite's Watertight Covers Chosen for Groundwater Collector at Paper Factory in Germany



Papierwerke Lenk groundwater collector

## Project Overview

The paper manufacturer, Papierwerke Lenk, located in a Southern region of Germany, produces a wide range of paper stocks. Water, required for paper production, is routed from the nearby river through pipelines under the foundation of the factory into a groundwater collector. This is encircled by a 90cm high enclosure to prevent splashes into surrounding area.

## Problem

The groundwater collector is located in the basement of the factory, alongside the waste processing plant. New government regulations require a watertight barrier between groundwater collection points and waste areas to protect the ground water effectively from splashes and penetration of paper sludge.



The blue epoxy resin is applied to the base



The aluminium frame is placed on the resin.

## Solution

KHK (a Fibrelite distributor based in Germany) proposed a simple solution using two Fibrelite FL900 sealed covers side by side (access to full clear opening was not required). Fibrelite's aluminium frames were attached to the base with a blue epoxy resin, completing the watertight seal. This allowed easy access to the opening for monitoring and maintenance while preventing penetration of paper sludge.

## Results

After less than two hours, the groundwater collector was successfully sealed with Fibrelite covers and epoxy resin and government requirements fulfilled.



Complete installed Fibrelite covers





**STADIUMS & LEISURE**

**FIBRELITE** 

**WE'VE GOT YOU COVERED**



# La Liga Stadium, Central Spain



## New La Liga Stadium in Central Spain Specifies Bespoke Fibrelite Trench Covers



Fibrelite trench covers installed at new Spanish stadium

### Project Overview

Bespoke Fibrelite GRP trench covers were specified by a new La Liga stadium in central Spain to provide protection and easy access to utilities (electrical, water and similar) in and around the stadium. In keeping with many Premier League stadiums, and leading architects and developers, this high profile La Liga venue was quick to embrace GRP composite technology in its infrastructure. In this instance, GRP trench covers provided a light, practical and proven alternative to traditional solutions in areas of high footfall.

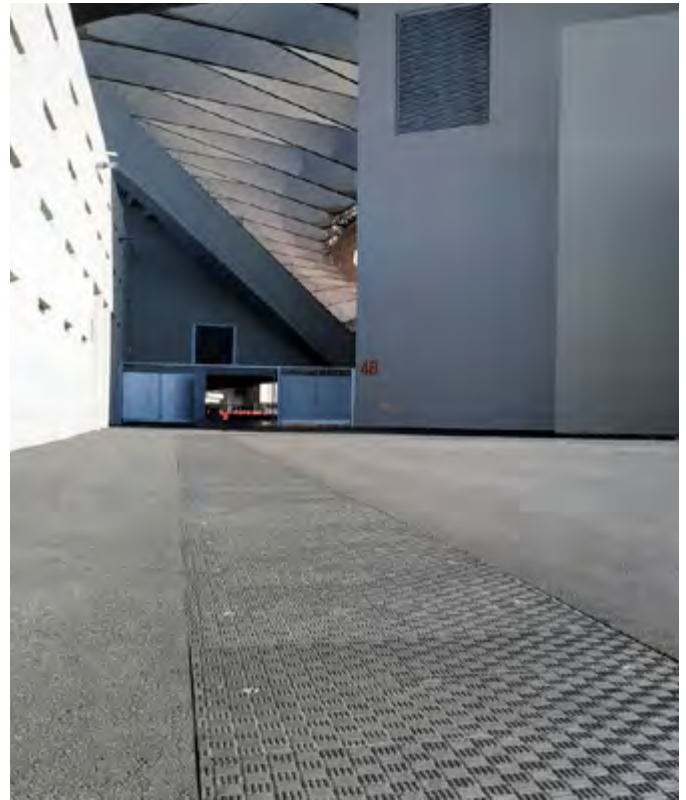

This project was completed within 2 months of the official PO

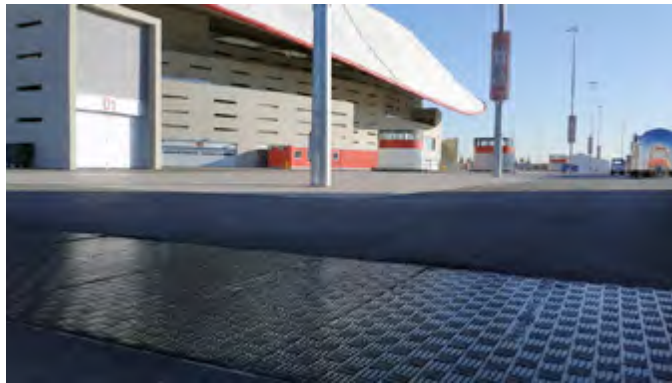

Fibrelite access covers provide a safe walking surface due to their unique tread pattern



All covers are safe and easy to remove manually by two people

### Problem

Conventional load-bearing access and manhole covers are heavy, susceptible to corrosion in harsh weather conditions and difficult to install and remove. The problem facing the stadium's architects and developers was how to retain the accessibility and strength, but improve the practicality, durability and performance.

The solution needed to be reliable, maintenance-free and long-term. It also had to take into consideration the safety of pedestrians walking over the covers, and simplify regular removal. In addition, the unique dimensions of the trench dictated a custom system of modular trench covers, with different load ratings in different areas: A15 load rated for pedestrian areas, C250 for the supplier entrance.



Fibrelite provided a custom system of lightweight modular GRP composite trench covers



## Solution

Having worked with leading clubs across the world, Fibrelite's flexible engineering and manufacturing departments were able to create custom designs to match the exact specifications required by the stadium. Like all Fibrelite covers, these are GRP composites which are lightweight, corrosion-free and safe to remove by hand. They also have a skid-resistant surface equivalent to a modern high-grade road, making them ideal for pedestrian areas.

Fibrelite regularly design high-performance, maintenance-free, trench covers for stadiums around the world, featuring club colours, team logos and bespoke designs.

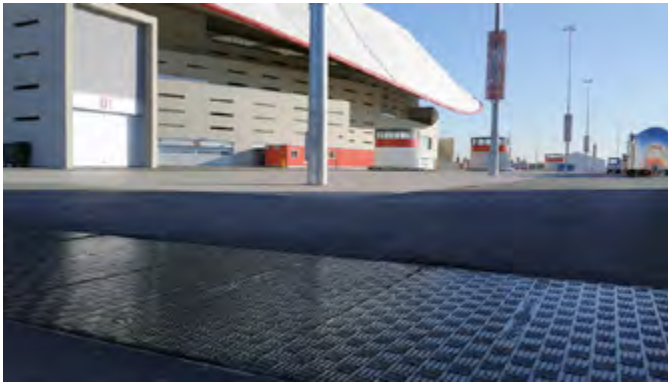

*Like all Fibrelite covers, these are GRP composite, lightweight, corrosion-free and allow safe removal by hand*

## Results

Thanks to Fibrelite's rapid design to delivery process, and a responsive local distribution network, the project was completed within two months of the customer securing the official purchase order. The stadium now has a safe long-term covering solution which will last for years to come.

## Theatre, Amsterdam, Netherlands

Fibrelite Trench Panels Installed at a Theatre near Schiphol Airport, thanks to TSE Fuelling Supplies, for Access to Geothermal Heating System

**FIBRELITE** 



Amsterdam Theatre

### Safer...Easier...Faster...Lighter

Previously a forklift was used each time access was required: an unnecessarily difficult and time consuming exercise. As quoted in the testimonial above, the customer was extremely pleased with the ease of manual handling that comes with these lightweight covers. The installation of Fibrelite Trench Access Covers has minimised the hazards involved, the time taken as well as the cost of removing the previously used large concrete slab. Two men, or women, using the Fibrelite FL7 lifting aids can now remove all of these covers safely, easily and within minutes.



Previously used time-consuming method of removing heavy concrete slab



The geothermal monitoring pit

### Installation of Fibrelite's Composite Trench Access Covers

This is a large pit (1.8 x 2m) used for access to a geothermal heating system underneath a theatre in Holland. The installation of a removable beam allowed for two rows of Fibrelite's B125 Trench Covers (able to withstand up to 12.5 tonnes of load) to be configured alongside each other, whilst not reducing the size of the clear opening.



The FL7 lifting aids allowing easy and safe removal

Customer Quote: "We are very happy with this solution. We do not need a forklift truck anymore to remove the concrete slab and can get to the geothermal installation in a minute. If I encounter a similar situation in the future, I surely will consider this option again."



# Leading Premier League Stadium, UK - Phase 1

## Fibrelite's Lightweight Coloured Composite Trench Covers Replace Damaged Steel Covers

Fibrelite's trench covers have recently been installed at a leading Premier League Stadium to replace damaged steel covers. The damage caused to the previously installed steel covers was caused by heavy vehicles requiring frequent access for concerts. The facilities management team at the Stadium also wanted to solve the manual handling and safety issues which were associated with the cumbersome steel covers previously in use.

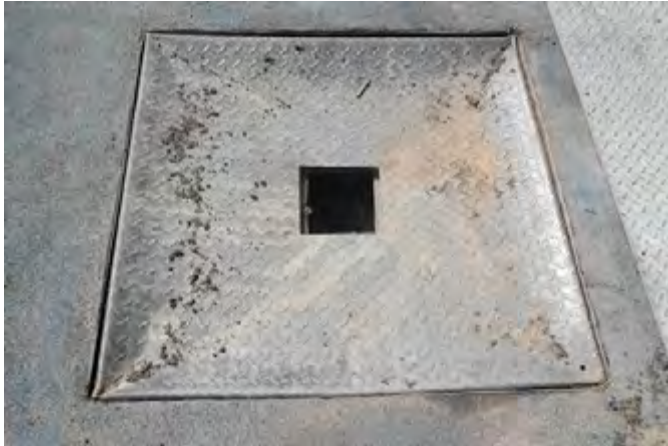

*Out with the old: the damaged reinforced steel cover to be replaced by Fibrelite's trench covers*



*Manual handling: the previously installed damaged cover required a hydraulic lifter to remove the cover*

### No More Manual Handling and Lifting Injuries

With Fibrelite's lightweight trench covers, which still reach the 10 tonne load capacity required, manual handling and lifting injuries are no longer an issue. The lightweight properties coupled with the ergonomically designed lifting aid, allows for a safe and easy removal of the composite trench covers.

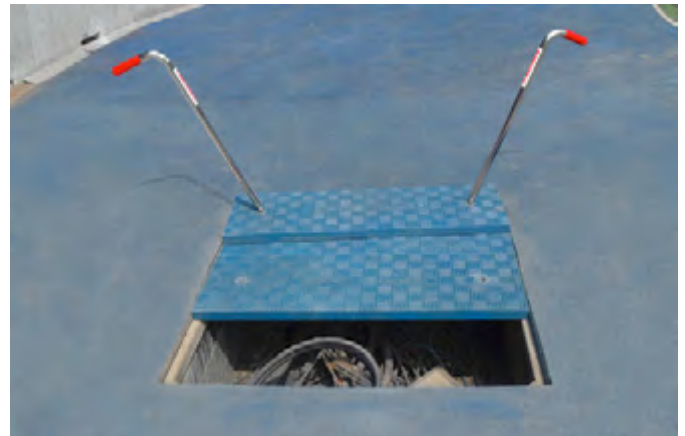

*Fibrelite's trench covers and ergonomically designed lifting aid allow for a safe and easy removal*

### Coloured Trench Covers

With many lengths, widths and depths of trench covers available together with the option of adding colour and logos, Fibrelite's trench covers offer an extremely versatile solution. All covers are BS EN 124 load rated, from A15 (1.5 tonne, pedestrian traffic) to E600 (60 tonne). Suitable for many applications ranging from stadiums, water sewage treatment plants, retail, industrial and commercial developments to airports, ports and dockyards.

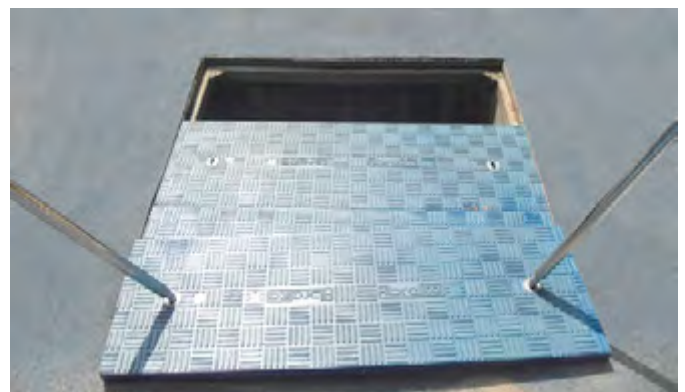

*The recently installed Fibrelite coloured trench covers*

Fibrelite can mould its composite covers in nearly any colour or combination of colours. The pigment is introduced directly into the resin during the moulding process, ensuring that the colouring is not merely applied to the surface but evenly and completely infused throughout the cover. This ensures that a coloured Fibrelite cover will not fade or wear over time.

## Leading Premier League Stadium, UK – Phase 2

### Fibrelite Continue Their Work Installing Coloured Trench Covers for Existing and New Camera Pits at a Leading Premier League Stadium

The composite trench covers were specified for the new and existing camera pits due to the manual handling issues experienced with the previously installed reinforced steel covers.



Large span: Fibrelite's trench covers go up to 1600mm in length at D400 (40 tonne) load rating

#### Coloured Trench Covers

An important requirement for this customer was that the trench covers were in keeping with the surrounding area. Any style logo or other marking can be permanently moulded into the upper surface of the cover in single or multiple colours. For additional brand or product identification, or to blend in with the colour or layout of a facility, Fibrelite can mould its composite covers in nearly any colour or combination of colours.



An existing camera pit to be covered by Fibrelite's composite trench covers



A camera pit to be covered by Fibrelite composite trench covers



The recently installed Fibrelite coloured trench covers, suitable for many applications ranging from stadiums, water sewerage treatment plants, to airports and dock and ports



The Fibrelite trench covers and ergonomically designed lifting aid allows for a safe and easy removal



## Benefits Overview

- Lightweight reducing lifting and handling issues: The covers are easily removed by a two man lift, even at heavy duty load ratings
- Improved efficiency and productivity: quick removal and no expensive lifting apparatus required, just the ergonomically designed Fibrelite lifting handle
- Corrosion resistant
- No resale value to the scrap market so will not be stolen
- Non-metallic and will not spark
- Composite is lightweight, strong and unlike concrete will not crumble or crack
- Guaranteed structural performance: All covers are tested to BS EN 124 standards



*Fibrelite trench covers have an anti-slip surface*

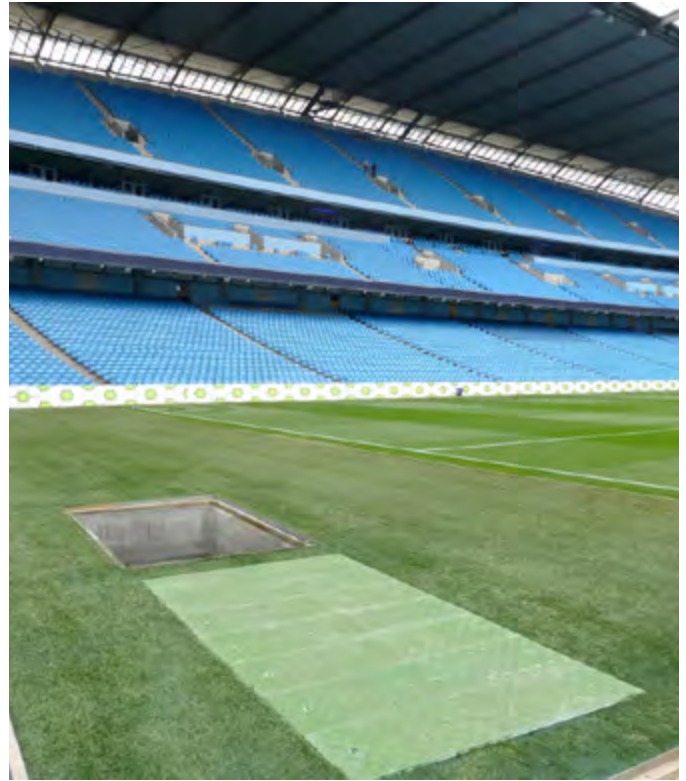

*Provided with a RAL number, Fibrelite can provide to any colour requirement*

# Football Stadium, London

Fibrelite Manufactures Bespoke 'Super Lightweight' Trench Covers for London Football Stadium



Fibrelite provided a long-term solution to accommodate the existing dimensions of the camera trench pits

## Project Overview

Fibrelite was approached by a third-party contractor on behalf of the client who was looking to replace their outdated camera pit covers at a football stadium in London, which were no longer meeting health and safety standards.

- Long term solution suitable for pedestrian traffic - approved in line with BS EN124 standards
- Fit into the existing dimensions of the camera trench pits
- Fibrelite covers have antislip properties equivalent to a high-grade road surface



The previously installed makeshift plastic decking had been deemed unsafe for pedestrian use

## Problem

The thin plastic decking was unsuitable for its intended use:

- Substandard material – lack of durability
- Covers had become warped and bent as a result of rainwater saturation
- Major health and safety hazard – entire trench area cordoned off, covers considered unsafe for pedestrians
- Lifting from the knees – unnecessary strain placed on the lower back due to the design of the covers

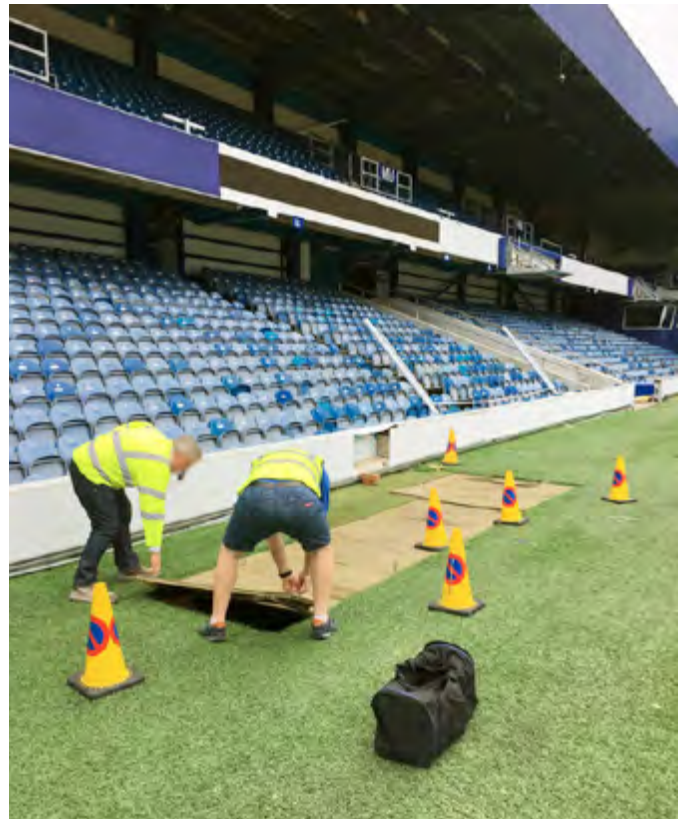

The existing covers had become a major health and safety hazard, with covers considered unsafe for pedestrians

## Solution

Fibrelite provided a bespoke covering solution for the client to meet their onsite requirements with no major upheaval to existing onsite facilities:

- 36mm deep Fibrelite A15 load rated trench covers and frame section
- Equipment was designed, manufactured & delivered to site in just over a month after the order was placed
- Blue coloured covers supplied as requested by the customer – Fibrelite covers can be manufactured in a range of different colours to suit customer requirements





*Fibrelite installed a range of lightweight covers which can be removed and replaced by two people using the ergonomically designed FL7 lifting handles*

## Results

Installation was completed in accordance with the client's construction programme, Fibrelite assisted with the process to ensure a smooth transition.

- The trench area can now be used by pedestrians safely without risk of failure and injury
- High strength to weight ratio
- Fibrelite's lightweight covers can be easily removed and replaced by two-people using the ergonomically designed FL7 lifting handles

# Leisure Centre, Sydney, Australia

Fibrelite Covers Provide Non-Corrosive Anti-Slip Access Solution for Sydney Leisure Centre



Leisure centre redevelopment Auburn, Sydney

## Project Overview

As part of the renovation of Auburn City Council's leisure centre, a simple access solution was required for access to the air conditioning system and balance tanks for the water set under around the perimeter of the pools. Previously, concrete covers had been used, however, poolside conditions are very hard on the metal that makes up the cover structure.



Hassle free and quick cover frame installation

## Problem

The original covers had corroded to a dangerous level, both for those removing them, and patrons walking around in bare feet. This was due to the omnipresent chlorine and moisture at this proximity to a swimming pool, which is corrosive to traditional concrete and metal access covers.

## Solution

Fibrelite's standalone covers proved the perfect solution. Composite covers are chemically inert, so have no reaction to either water or chlorine, meaning that the covers will remain watertight and safe to walk on year on year. They are also lightweight, so can be safely and quickly removed by one person using the ergonomically designed FL7A lifting handle. Fibrelite provided a custom coloured solution to blend in with the surroundings. The patented monolithic structure of the covers means that they will not crack or delaminate or fade, as tested by BSI.



Installed cover over balance tanks





Watertight FL900 B125 cover



Bespoke coloured cover to match floor

#### Now Allowing Easy and Safe Access

Fibrelite recently supplied a private vineyard in Jersey with lightweight composite access covers. Another first! The Fibrelite covers are now fully installed and have been used specifically to cover manifolds for a ground source heating installation with buried pipes between the rows of vines. Fibrelite was specified by Richard Le Sueur Architects.

Fibrelite's composite access covers are lightweight, durable and very strong. Every Fibrelite cover is manufactured using high-technology RTM production methods to create a highly engineered, monolithic composite product.

Fibrelite has established a global reputation for high quality products and superior after sales service. The company has held accreditation to both the ISO quality standard and British Standards Kite Mark since 1998.

Composite covers have always been seen as a high cost alternative to traditional metal products. However, with Fibrelite's technological advances in the manufacturing process, the development of our B125 covers and rising metal prices, composite can now compete head to head with the likes of cast iron.

Composite covers are now being used in a wide range of applications and are ideal for access to sewage systems, underground pipework, drainage networks, electrical junction boxes, water treatment plants and commercial fuel storage.

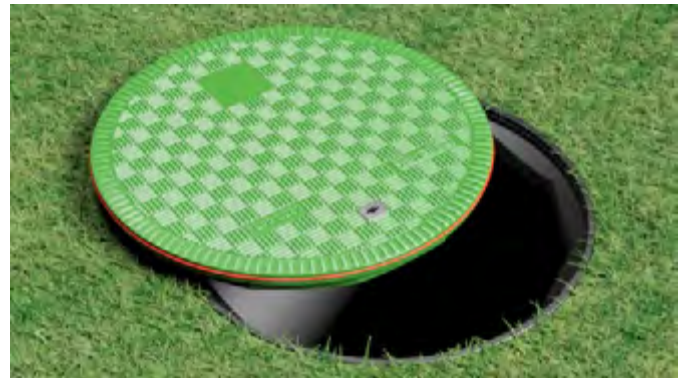

*Fibrelite composite cover - green colour option*

#### Lightweight Without Compromising on Strength

Fibrelite composite covers are tested to BS EN 124 and are available with load ratings from B125 up to F900 depending on the application. They are lightweight, strong, easily removable and available in a wide range of sizes.

The patented monolithic structure of a Fibrelite cover means that they will not crack or delaminate during usage. They are also chemically inert and have zero scrap value meaning Fibrelite composite covers are an increasingly popular choice over metal covers.



# Leisure Centre, Keighley, UK

Fibrelite Provides Non-Corrosive, Anti-Slip Access Solution for Leisure Centre Poolside



Fibrelite cover chosen for poolside at local leisure centre (Image credit: Betty Longbottom)

## Project Overview

Fibrelite was recently commissioned to replace a corroded metal access cover pool side at a local leisure centre in Keighley.

## Problem

Poolside conditions are very demanding for traditional metal access covers due to the constant moisture in the air and exposure to chlorine which both cause corrosion. The cover must also be safe for the public to walk over in bare feet without slipping, or cutting themselves due to rust. The equipment underneath must be protected from water, and easily be accessed by one person.



Leisure centres are highly corrosive environments with moisture and chlorine, making composites an obvious choice



Fibrelite's FL96 watertight manhole cover installed

## Solution

Fibrelite's standalone sealed manhole cover (FL96) proved a perfect solution for Keighley Leisure Centre. The cover has a watertight seal to protect the equipment underneath from water infiltration which it achieves without bolts, and is lightweight enough to be safely removed by one person with the FL7A lifting handle. Fibrelite's composite covers have an inherent resistance to corrosion, so are ideal for use in highly corrosive environments like leisure centres. This means that the cover will remain watertight and safe to walk over year on year. All covers come with an anti-slip tread pattern as standard, proven to surpass health and safety advisory conditions, ensuring safety for those walking over it.



Fibrelite's fit and forget, glass reinforced plastic (GRP) composite cover fitted in Keighley leisure centre



Lightweight Fibrelite covers

The architects (Foster Wilson Architects LLP) who were project managing the refurbishment of the theatre tasked with providing a discreet and practical method of housing multicore cables that ran from the stage to the control desk during music concerts. Previously the cables had been run above ground subsequently causing damage to the beautiful interior of the theatre.

To accommodate the multicore cabling, two underground cable routes were cut into the floor. The cable routes needed to be covered with a lightweight maintenance free, cover that was readily removable by simple manual handling techniques but also sufficiently strong enough to withstand imposed loads from MEWP's (mobile elevating working platforms) as additional refurbishment work on the building was required.

In addition to these requirements anti-slip/skid was also a factor that need to be addressed.

#### No Compromise on Performance

Upon request, Fibrelite can provide bespoke and custom solutions. This means that the panel dimensions, internal stiffeners and fibre architecture can be altered to optimise the performance of each panel based on project specific design criteria.

Fibrelite supplied a bespoke encapsulating frame for both multicore cable routes along with a 1.5 tonne load rated trench cover to cover the cable trenches. The design was extremely challenging as not only did the cable trenches change in direction but they also changed in elevation. The Fibrelite cover incorporates an anti-slip material within the top treaded surface of the covers which provides unparalleled anti-slip/skid properties for a composite cover.



Easy single person lifting system

Fibrelite attended site regularly throughout the installation and liaised with both the architect and principle contractor to provide a solution to the highest possible standards within the projects build time frame. The lead Architect, project managing the refurbishment commented on the solution provided by Fibrelite: "Overall I think Fibrelite is a great solution to a difficult design problem for us of achieving both a robust and high load capacity cover to the multicore cables running for stage to control desk whilst maintaining low weight and easy access"

#### Sophisticated Highly Specialised Material

Fibrelite is the world leading manufacturer of glass reinforced plastic (GRP) composite manhole covers and trench covers. This sophisticated and highly specialised material is fast becoming recognised as the more effective modern alternative to traditional materials such as heavy steel and concrete. Benefits over the more traditional, technologically inferior metal covers:

- Lightweight for easy and safe manual removal
- Load ratings from A15 to F900 (BS EN 124)
- Chemically inert and corrosion resistant
- Anti-slip/skid properties





*Fibrelite covers have an anti-slip surface*

### **Benefits of Fitting a Fibrelite**

- Customised solutions
- A fit and forget product that will not corrode or fade
- Improved productivity for both operational and maintenance crews
- Improved health and safety practices
- Technical support

### Fibrelite's Trench Covers Specified for a Brand New Restaurant Opening at London Zoo

Fibrelite's heavy duty composite trench covers have been specified for expansion work at London Zoo. The newly installed D400 trench panels are lightweight while maintaining the all-important strength properties of a 40 tonne load rated cover.

The trench covers provide easy and safe access to the ducting below and are regularly driven over by heavy goods vehicles. Designed as a 'fit and forget' product, the maintenance free Fibrelite trench panel is perfect to cover large areas that require frequent or occasional access.

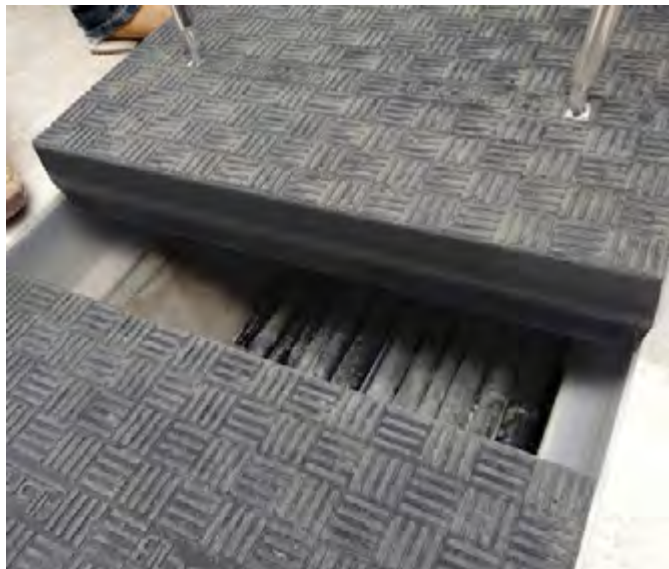

*For ease of installation and to provide a better seating face, a specially designed aluminium frame can be provided*

#### The Versatile Trench Cover

With ranging widths, depths and lengths available together with the option of coloured covers and logos Fibrelite trench covers are extremely versatile. All covers are BS EN 124 load rated, from A15 (1.5 tonne, pedestrian traffic) to E600 (60 tonne). Suitable for an extremely broad range of applications including water treatment plants, stadia, hospitals, airports, ports, dockyards, retail and industrial developments.

Fibrelite can provide to any requirement you may have, supplying the truly versatile trench cover



*Fibrelite's trench covers available in various depths, widths and sizes*

#### Summary of Composite Benefits Versus Steel and Concrete

- Improved health and safety, safe manual handling
- Improved efficiency and productivity
- Airtight and watertight
- Corrosion resistant
- Resistant to aggressive chemicals
- No resale value to the scrap market so will not be stolen
- Non-metallic and will not spark
- Composite is lightweight, strong and unlike concrete will not crumble or crack



*Fibrelite's ergonomically designed lifting handle make for easy and safe removal and entry to the ducting below*





**FOOD PROCESSING**

**FIBRELITE** 

**WE'VE GOT YOU COVERED**

Fibrelite Supply Composite Access Covers to Replace Heavy Odour-Emitting Galvanised Covers



Newly installed Fibrelite flat sealed FL140 composite covers



Unsafe lifting of the old covers - health and safety hazard

## The Problem... Odour Emitting Heavy Galvanised Covers



Previously installed odour-emitting galvanised covers

A solution was needed to solve the problems caused by the previously installed galvanised covers used to cover a 2800 x 1400mm grease pit. These covers claimed to be odour tight but weren't, resulting in the constant emission of a terrible odour. The heavy galvanised covers were also extremely difficult to remove and caused other health and safety issues as they were slippery when wet.

Fibrelite's light but strong; slip resistant flat sealed composite covers were specified to eliminate all of these hazards.

Fibrelite supplied a flat sealed solution of FL140/B125 load rated covers (1400 x 700mm) configured alongside one another and sealed in between each frame.

- Completely odour tight
- Easy removal for one person
- No hinges/mechanical struts or gas assist lifts required
- Slip resistant
- Aesthetically pleasing - orange covers requested

## The Solution... Installation of Fibrelite's Composite Covers



Fibrelite's odour tight composite covers

## Now Allowing Easy and Safe Access

Fibrelite's composite access covers are lightweight, durable and very strong. Every Fibrelite cover is manufactured using high-technology RTM production methods to create a highly engineered, monolithic composite product.

Composite covers have always been seen as a high cost alternative to traditional metal products. However, with Fibrelite's technological advances in the manufacturing process, the development of our B125 covers and rising metal prices, composite can now compete head to head with the likes of cast iron and steel.

Composite covers are now being used in a wide range of applications and are ideal for access to sewage systems, underground pipework, drainage networks, electrical junction boxes, water treatment plants and commercial fuel storage.





**RAIL, TRAMS & UNDERGROUND**

**FIBRELITE** 

**WE'VE GOT YOU COVERED**

# Rail Maintenance Facility, Doncaster, UK



Fibrelite's Custom Designed Covers Provide Lightweight Solution for £70 Million Doncaster Rail Maintenance Facility



Bespoke Fibrelite covers made to the exact specifications of the customer



Fibrelite was approached to provide a custom long-term solution

## Project Overview

Rail maintenance facilities are busy places where safety and efficiency are key. These facilities include large machinery, vehicles carrying heavy loads and have essential services housed below ground which must safely and frequently be accessed. Fibrelite was approached to provide a custom long-term solution.

## Problem

This Doncaster rail maintenance facility required custom-made trench covers to accommodate a selection of different sized piping which need to run vertically through the covers and into the trenches. The trench covers also needed to be manufactured to custom dimensions to fit perfectly around corners, buildings and machinery.

The covers needed to be strong while enabling quick, safe, regular access for essential maintenance and monitoring. Due to frequent wet weather conditions, the covers needed to have sufficient anti-slip properties to ensure the safety of people walking around the site.



Fibrelite trench covers provide a safe walking surface even when wet

## Solution

Fibrelite's UK technical team (based in Skipton) worked closely with engineers and contractors at the Doncaster facility to design and manufacture tailor-made covers which accommodate the service pipes to the exact specifications of the customer. Trench covers were made in two load ratings; D400 for areas outside of the facility and B125 for the inside.

Fibrelite covers have the best strength-to-weight ratio in the industry, which means they can support large machinery and vehicles carrying heavy loads while being light enough to be removed easily and safely by two people using specially designed lifting handles.

The trench covers also provide a safe walking surface even when wet which has been tested to be equivalent to a modern, high-grade road surface. Manufactured using a specialised composite material, they will not corrode over time, unlike metal and concrete, meaning that they will not need to be replaced for many years.



Fibrelite covers will not corrode over time, unlike metal and concrete





*Two different load rated covers were used for the installations, B125 and D400*



*Fibrelite covers can accommodate service pipes of all shapes and sizes*



*Fibrelite provided a tailormade long-term solution*

### **Results**

This Doncaster maintenance facility now has a long-term access solution that eliminates manual handling problems while improving the overall efficiency and effectiveness of the site.

### Project Overview

As part of a platform upgrade programme, Colt Construction (Principle Contractors) approached Fibrelite looking to replace and colour match Darlington railway stations broken and damaged recessed covers which provide access to electrical services, CCTV and telecommunication cables, within a tight timeline.



Colt construction were carrying out a platform upgrade programme

### Problem

Colt Construction were looking to upgrade the broken and damaged recessed covers which had become difficult to remove and replace for maintenance purposes. Darlington railway station is a listed building which meant that the covers needed to match the surrounding floor tiles, whilst preventing unauthorised access and providing a safe walking surface for station users.



Fibrelite covers provide a safe walking surface for station users

### Solution

Colt Construction provided a sample of the flooring, enabling Fibrelite to supply covers which matched the base colour of the tiles. The B125 load rated covers were bolted down, preventing unauthorised access. The anti-slip surface of the covers provides a safe walking surface for station users, installation was completed within the tight timeline.



Fibrelite supplied covers which matched the base colour of the tiles



Fibrelite's bolted covers prevent unauthorised access

### Results

Darlington railway station now has a long-lasting colour matched solution which enables safe and easy access to electrical services, CCTV and telecommunication cables. Preventing unauthorised access and providing a safe walking surface for station users.



## Fibrelite's Lightweight Composite Covers Eliminate Manual Handling Issues in Oldham



Oldham Metrolink with Fibrelite covers

### Project Overview

Tram platforms are very busy areas where safety and efficiency is key. The highly trafficked area means that a safe walking surface is required and the frequent need to access underground utilities makes a time saving solution highly beneficial for this type of environment. Here Fibrelite provided an effortless and safe solution.

### Problem

Originally, concrete recess covers had been fitted on Oldham's Metrolink platform over essential utilities. These were extremely difficult to move due to their weight, increasing the risk of manual handling injuries. Specialised lifting equipment was needed every time access was required, making the process expensive and time-consuming. Oldham Metrolink were looking for a safer simple solution to replace the access covers. Maintenance time needed to be kept to a minimum to avoid disruption to the live platform which is used daily. Covers also had to be securable to prevent unauthorised access as they were over live electric cables.



The previously installed heavy concrete covers

### Solution

Fibrelite designed and manufactured bespoke grey composite covers to fit directly into the existing frames and to match the surrounding area making installation quick and easy. This enabled the tram service to continue as normal with minimal disruption. Fibrelite covers are corrosion-free, lightweight and securable. Requiring no maintenance and can be safely lifted by two people using the ergonomically designed FL7A lifting handle. This allows users to safely remove and replace the securable covers, preventing manual handling injuries by lifting from the waist. Fibrelite covers have been engineered to provide a safe walking and driving surface, tested to be equivalent to modern high-grade road surfaces. Meaning that...



Fibrelite's lightweight securable composite covers

### Results

Oldham station now has a long-term solution that will continue to perform year after year. The lightweight composite access covers provide safe and fast authorised access, whilst eliminating previous manual handling issues and provide a safe walking surface for station users in every weather.



Fibrelite covers provide a safe walking surface in all weather conditions

# Railway Maintenance Depot, London, UK



Fibrelite Supply Lightweight Cable Trench Covers to One of UK's Largest Railway Maintenance Depots



*Railway Maintenance Depots*

Fibrelite's bespoke lightweight composite trench covers have recently been installed over a service trench at the primary railway maintenance depot for the Docklands Light Railway. These were installed to give quick and easy access to the service trench.

## The Problem

Fibrelite had two major issues to deal with when installing and manufacturing the retrofit solution. Firstly, the concrete rebate was dimensionally inconsistent throughout, causing an undulating surface. Secondly, high and low voltage cables running through the trench also had to come out of the trench to the switch boards in various positions along the trench.



*High and low voltage cables leaving trench to switchboard at regular intervals*

## The Solution

Fibrelite supplied and installed an encapsulating frame that directly fitted into the existing rebate. Fibrelite's experienced site team was able to provide a solution to correct the inconsistent trench using Epoxy Resin to level the surface to ensure the frame and trench panels fitted flush.

Fibrelite also manually cut and re sealed the appropriate trench panels allowing the electricity cables to run out of the trench to reach the correct switch boards.

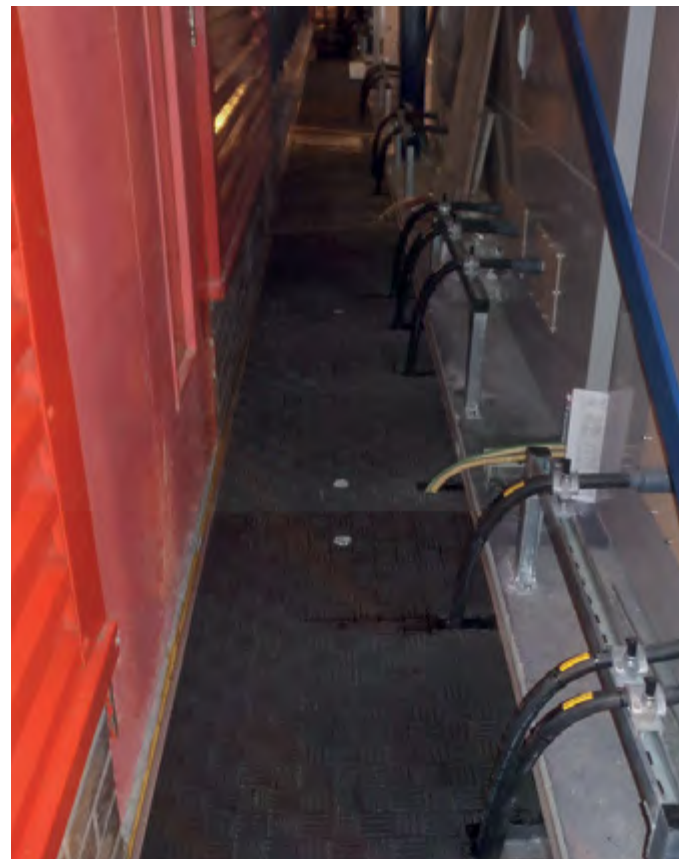

*Trench panels cut and re-sealed on site allowing cables to run through*

## Results

This retrofit project presented a number of challenging problems which needed to be overcome. Fibrelite designed and manufactured large bespoke panels the longest of which was 1.6 m long, reducing the total number of panels required to cover the trench.

Fibrelite's dedicated team of site engineers assisted with the installation of the covers, as they were required to be cut and re-sealed to accommodate service cables.

This project was completed in short amount of time, making the installation process both quick and efficient, which is just one of the many benefits of choosing Fibrelite.





*Expansive trench requiring coverage*



*Custom made covers fit the trench and cabling entry points perfectly*

# Newcastle Train Station, UK



## Fibrelite On Track with Lightweight, Composite Trench Covers for a Major UK Rail Station's Platforms



*Fibrelite covers feature an anti-slip surface*

Fibrelite has recently developed a range of bespoke, lightweight, composite trench covers, dramatically reducing the cost to cover larger openings. These bespoke covers have recently been installed over access hatches in the platform of a major UK rail station to give quick and easy access to services below platform level.

### Lightweight Bespoke Covers – Easy and Safe Manual Handling

Fibrelite solved the manual handling issues by designing lightweight, composite trench covers in bespoke sizes, supplied complete with aluminium frames. These larger sizes allowed for fewer panels to be used to cover the openings, reducing overall cost of replacement, while still remaining light enough for easy and safe manual handling. Fibrelite's composite trench covers offer the best strength to weight ratio in the industry, easily achieving the BS EN124 B125 load rating required for this application. In addition to this, Fibrelite covers come as standard with an anti-skid finish, a major consideration in a rail platform environment.

### Key Fibrelite Benefits for this Project

- Lightweight for easy and safe manual removal
- Bespoke sizes available for large or complex projects
- B125 covers selected from Fibrelite's range cover A15 – F900 (BS EN 124)
- Anti-slip surface



*Lightweight Fibrelite covers now installed on platform*

### Heavy Covers Causing Manual Handling Issues



*Previously installed, heavy, difficult to lift concrete covers*

The covers on the platform provide essential access to services housed below the platform level and are lifted regularly, so routine maintenance work can be carried out. The previously installed covers were heavy, concrete infilled covers which proved very difficult to remove and presented serious manual handling issues to operatives. Removing the covers was a costly and time consuming process, with specialist lifting equipment often required.



## Fibrelite Supply Bespoke Trench Covers and Frames to the New Nottingham Tram Development



*The Fibrelite B125 (12.5 tonne) load rated medium duty trench access covers*



*Fibrelite covers needed to be manufactured to work with pre-installed chamber systems*

### Fibrelite Supply Trench Covers to Leading Construction Company

Fibrelite developed a completely bespoke cover and frame for this complicated application. The main requirement was easy access for operators who regularly need to enter these feeder chambers that supply the overhead lines to power the Tram. The covers were designed as a large one piece cover to sit exactly over the electrical chambers. Due to the very public areas that will eventually be a station platform the covers needed to be non-slip and lockable. Each cover has a tread pattern incorporated with anti-slip / skid properties and each cover had 4 locks moulded in for additional security. The panels are lifted regularly to ensure services are working efficiently. For operators working on the development, ease of access and safety are critical.



*Bespoke trench covers for trackside gear*

Fibrelite's access covers are lightweight, durable and very strong. Every Fibrelite cover is manufactured using high technology resin transfer moulded (RTM) production methods to create a highly engineered, monolithic composite product.

### No Compromise on Performance

Upon request, Fibrelite can provide bespoke and custom solutions. This means that the panel dimensions, internal stiffeners and fibre architecture can be altered to optimise the performance of each panel based on project specific design criteria.

### Customised Solutions from Fibrelite

Due to the complexity of this application, the covers were pre-made with the frames and locks in Fibrelite's UK Manufacturing Facility. This meant each of the forty four covers would be exactly the same and meant continuity of quality. For Fibrelite the challenge was to design the trench covers to fit an existing chamber that had been designed for an alternative solution. Working to an extremely tight deadline and challenging conditions, Fibrelite manufactured a completely bespoke trench cover arrangement. Widths and depths had to be changed and panels cut to exact dimensions to accommodate locking mechanisms. Fibrelite's lightweight medium duty composite trench cover was identified as the solution. Designed as a 'fit and forget' product, the maintenance free covers provide easy and safe access to the essential pipework.

### Sophisticated Highly Specialised Material

Fibrelite is the world leading manufacturer of glass reinforced plastic (GRP) composite manhole covers and trench covers. This sophisticated and highly specialised material is fast becoming recognised as the more effective modern alternative to traditional materials such as heavy steel and concrete.

Benefits over metal and concrete covers:

- Lightweight for easy and safe manual removal
- Load ratings from A15 to F900 (BS EN 124)
- Chemically inert and corrosion resistant
- Anti-slip/skid properties

### Highly Effective in Preventing Heavy Lifting

Fibrelite's trench covers have proved highly effective in reducing health and safety issues and potential damage to essential pipework.

### Benefits of Fitting a Fibrelite

- Customised solutions
- A fit and forget product that will not corrode or fade
- Improved productivity for both operational and maintenance crews
- Improved health and safety practices
- Technical support

## Fibrelite Begin Supply of GRP Composite Covers to Large Scale Rail Project

### Non-Sparking Fibrelite Preferred for Railway Station Platform

Fibrelite is in the process of supplying the first 20no. 900 x 450mm medium duty GRP composite covers for this large rail project. These lightweight covers will be used to provide easily access to electrical junction boxes and cable drawpits containing signalling equipment on the station platform.



Section of train station platform with 4 covers (mid-way through install)

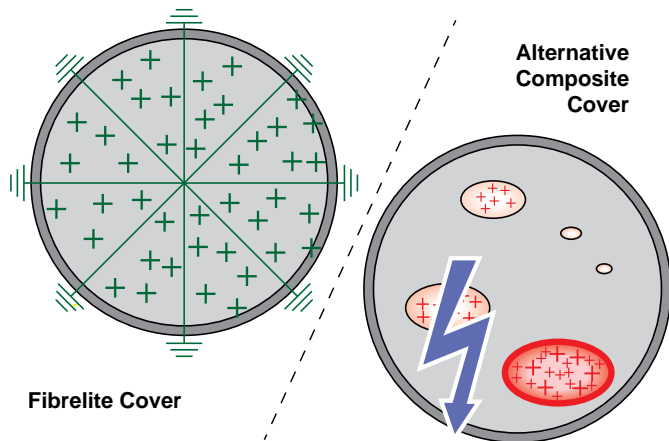

Comparison between the localised pockets of charge in an alternative and the Fibrelite cover, which immediately grounds any build-up of static

### Fibrelite Specified for Anti-Static Properties

Potential electrostatic discharging can be eliminated by using the “fully conductive” Fibrelite composite cover. By using a metalized fibre within the moulding process we can achieve electrical continuity across the entire surface of the cover, which results in the Fibrelite covers exceeding the surface resistivity requirements of PAS26. The standard calls out for a maximum value of 1 KΩ/cm<sup>2</sup>, the Fibrelite cover actually achieves a value of 0.0144 KΩ/cm<sup>2</sup>

### Other Benefits

Fibrelite also preferred for the following benefits:

- Lightweight covers enable easy and safe manual handling during install, particularly alleviating issues with steep train line embankments, tracks or stairs to the platform
- Zero resale value to the scrap market so will not be stolen
- Anti-slip Properties: Fibrelite covers exceed the minimum slip resistance requirement of BS EN124/PAS26, HA104/09: Part 5 and the UK HSE minimum slip resistance guidelines when tested in accordance with BS EN13036-4:2011
- Will not corrode



Fibrelite FM45-B125 trench cover





**ROAD & ROADSIDE**

**FIBRELITE** 

**WE'VE GOT YOU COVERED**

# Access Pits, Kuala Lumpur, Malaysia

Fibrelite Covers Provide Safe Hardwearing Solution for Access Pits Set in Major Kuala Lumpur Road



*Jalan Jelatek, Kuala Lumpur*

## Project Overview

Water mains in cities are traditionally run under roads to allow for maintenance. At regular intervals along the pipes, valves are located to regulate or shut off water flow in the event of a leak or other necessary work. Valves are set in access pits in the road (often the middle or side) under access covers. These must withstand daily traffic including heavy goods vehicles, while being easily removed quickly to minimise disruption.



*Previously installed steel access pit over water mains valve*

## Problem

Fibrelite were called upon to offer a solution for two such access covers in Jalan Jelatek, a central area of Kuala Lumpur which were regularly trafficked by cars and heavy goods vehicles with estimated loads of up to 40 tonnes. When access was required to valves, one lane (road edge cover) or the entire road (road centre cover) had to be closed off, and traffic re-routed. Previously installed modular metal covers were time consuming and hazardous to remove due to their weight, multiple sections and corroded edges. Corrosion also resulted in a less than perfect fit, allowing water ingress into the access pit. Due to its location, the cover also needed to provide an anti-skid surface for cars and a safe walking surface for pedestrians crossing the road.

There was also a concern about theft of the metal covers, following a number similar thefts in the area leaving dangerous exposed openings

Due to the central location, it was crucial that replacement was completed within a very tight timescale.



*Prefabricating concrete plinth with Fibrelite FL90 frame*



*Fibrelite tread pattern provided the perfect slip resistance required*

## Solution

After surveying the site to assess the existing substrate, the contractor arranged to have specific reinforced isolated concrete slabs factory-manufactured to the Fibrelite design specification. Apertures were then cutting in the existing road surface to accommodate the concrete slabs. The new concrete slabs with Fibrelite's FL90 D400 and frame were then positioned into the openings. The D400 load rated FL90 covers handle up to 40 tonne loads (independently tested to EN124) while being safely manually removed by a single operator. The FL90 covers and frames provide a watertight seal and the 900 mm opening offers ample room for access.

The standard Fibrelite tread pattern provides the perfect slip resistance required for a safe walking surface, with test reports demonstrating that even when wet, Fibrelite covers have anti-slip properties equivalent to a modern high grade road surface, far exceeding health and safety advisory limits.





*Modular metal covers time consuming and hazardous to remove due to weight, multiple sections and corroded edges*



*All sealed Fibrelite covers can be safely manually removed by a single operator*



*Plinths ready for installation*



*D400 load rated FL90 covers tested to EN124*

## Results

Fibrelite's FL90s allow quick and easy access to valves beneath, minimising the amount of time required to close the road when maintenance is required. All Fibrelite's sealed covers can be removed safely by a single operator.

The composite cover and frame create a watertight seal preventing surface water ingress into the access pit, while their inherent resistance to corrosion ensures the covers will provide problem-free years of service.

The risk of theft is minimised. Fibrelite covers have no scrap value, and unauthorised access without a Fibrelite lifting handle is very challenging.

# Hammersmith Flyover Bearing Pits, London, UK



Fibrelite Trench Covers Provide an Engineered Covering Solution Over Bearing Pits for Iconic Hammersmith Flyover in London



London Hammersmith flyover during refurbishment



Bespoke composite trench covers designed with encapsulating frames

## Project Overview

As part of the essential refurbishment and strengthening of this iconic London flyover, roller bearings at the base of the supporting piers were replaced due to wear, corrosion and the ever increasing vehicular traffic volume. The replacement spherical sliding bearings are located in underground bearing pits, which are now covered by an encapsulating row of bespoke GRP trench covers. The cover design layout accommodates minor movement of the pier.

## What Was the Problem?

The previously installed concrete recess covers were cumbersome, preventing easy inspection and maintenance access to the bearing pits. They also exhibited major fatigue. A solution was required in specific sizes with a securing mechanism to prevent unauthorised removal of the covers, while allowing easy access when essential maintenance was required. As the covers would potentially experience both pedestrian foot traffic and the occasional vehicular wheel the covers had to be designed for both environments.

## What Was the Fibrelite Solution?

Fibrelite worked in close collaboration with the designing engineers (Ramboll) and the installation contractor (Pro Steel) to design, manufacture and deliver a custom made covering solution for the 15 piers, totalling 500 individual GRP trench covers encapsulated within a purpose designed frame. The bespoke GRP trench covers were equipped with locking device to prevent unauthorised access.

Handling pedestrian and vehicle traffic was achieved by supplying a C250 (25 tonne) load rated cover with a unique anti-slip/skid tread pattern surface.



Lightweight tailor made Fibrelite covers set into frame around supporting pier

## Results

Fibrelite's GRP composite access covers have an inherent resistance to corrosion, offering a maintenance free 'fit-and-forget' solution. This means when you fit Fibrelites, they will continue to perform over time and retain their snug fit, minimising water ingress. When essential maintenance is required, the lightweight trench covers can quickly, safely and easily be removed using the custom 'key' and Fibrelite's ergonomically designed lifting handles. Fibrelite's GRP covers also have anti-slip properties equivalent to a modern high grade road surface whether wet or dry, far exceeding health and safety advisory limits [independent test reports] providing a safe walking surface. All Fibrelite access covers are BS EN 124 load test compliant, meaning consistent high quality is assured.





*Roller bearings at bases of supporting piers before being replaced*



*Securing system moulded into covers which locks into frame, preventing unauthorised access*



*Replacement bearings located in the underground pits, covered by continuous set of access covers, allowing for the minor movement of the pier*



*Spherical sliding bearings located in underground pits, allowing for minor movement of the pier*



*Roller bearings at the bases of supporting piers were replaced due to wear and increased load on the bridge*



## M4 East Bound, Newport, UK

Fibrelite Supply Trench Covers Over Chamber Systems That House Communication Cables and CCTV Camera Systems



The Fibrelite B125 (12.5 tonne) load rated lightweight trench access covers

### Fibrelite Supply Trench Covers for M4 East Bound at Newport

Fibrelite's range of covers offer easy access for operators who regularly need to access these chambers that house communication cables and CCTV camera cables. Due to the nature of what is underground the covers need to be easy access for operators who regularly check and monitor the equipment. For operators working at the roadside in all weathers and often at night, ease of access and safety are critical.



Fibrelite covers will not corrode, crumble or crack

Fibrelite's access covers are lightweight, durable and very strong. Every Fibrelite cover is manufactured using high technology Resin Transfer Moulded production methods to create a highly engineered, monolithic composite product.

### Damaged Cast Iron and Concrete Covers Replaced

The previously installed, heavy and damaged cast iron and concrete covers caused a health and safety issue and needed replacing. Fibrelite's lightweight medium duty composite trench cover was identified as the solution. Designed as a 'fit and forget' product, the maintenance free covers provide easy and safe access to the essential cabling.



Heavy covers present a hazard for operators



Damaged cast iron and concrete cover

### Highly Effective In Preventing Water Ingress

Fibrelite's sealed covers have proved highly effective in preventing water ingress and subsequent damage to essential valve equipment.



## Sophisticated Highly Specialised Material

Fibrelite is the world leading manufacturer of glass reinforced plastic (GRP) composite manhole covers and trench covers. This sophisticated and highly specialised material is fast becoming recognised as the more effective modern alternative to traditional materials such as heavy steel and concrete. Benefits over metal and concrete covers:

- Lightweight for easy and safe manual removal
- Load ratings from A15 to F900 (BS EN 124)
- Chemically inert and corrosion resistant
- Anti-slip/skid properties

## No Compromise on Performance

Upon request, Fibrelite can provide bespoke and custom solutions. This means that the panel dimensions, internal stiffeners and fibre architecture can be altered to optimise the performance of each panel based on project specific design criteria.

### Benefits of Fitting a Fibrelite

- Customised solutions
- A fit and forget product that will not corrode or fade
- Improved productivity for both operational and maintenance crews
- Improved health and safety practices
- Technical support

### Turnpike Authority Chooses Fibrelite Corrosion Resistant Composite Manhole Covers for Highway Expansion Project



*Turnpike Authority Chooses Fibrelite*

This is a multi-year project and several hundred manholes will be installed during the widening of the turnpike and related construction.

#### Now Allowing Easy and Safe Access

Fibrelite's lightweight GRP manhole covers were identified by an engineering consultant working for this particular Turnpike Authority. The requirement was for a 40" diameter composite manhole cover that could be used for roadway lighting pole manholes (these manholes contain the electrical wiring used to power the 40" high light poles).

Roadway lighting pole manholes are installed next to the highway and are therefore exposed to the corrosive salt applied to the highway to melt snow and ice during the winter months.

As composite manhole covers are highly resistant to corrosion, the Turnpike Authority asked the engineering consultant to locate a composite cover capable of withstanding H25 load ratings without failure.

Fibrelite worked with Turnpike Authority to develop a 40" diameter, heavy duty GRP composite manhole cover that was load rated to 40 tons without failure.



An Atlanta based engineering firm asked Fibrelite to solve a problem for the CDC location in Atlanta Ga. The facility has a new diesel fuelling facility where vehicles are fueled. They wanted to have easy access to their overspill vault set across the street from the loading facility.



*Road before concrete vault and trench cover installed*

Fibrelite's heavy duty trench covers to be installed directly on a newly made concrete trench crossing the street.



*Pre-install location for the Fibrelite covers*

Heavy duty trench on the street allows street traffic to drive over and offers a low weight solution to the Center of Disease Control's complex needs. Fibrelite's range of heavy duty covers were designed for such an application. The main requirement for access the containment vault were met.

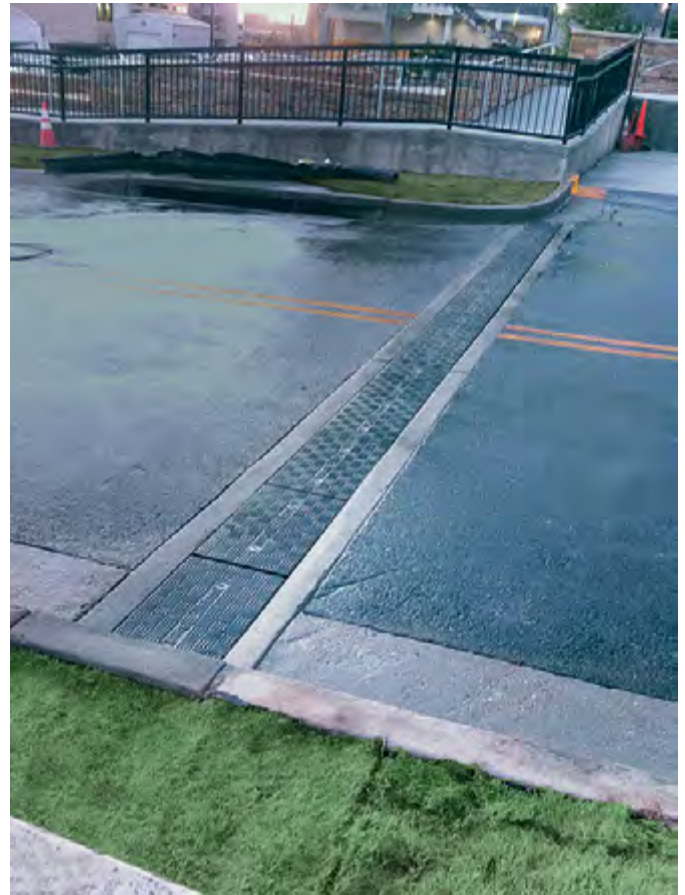

*Fibrelite covers offer a clean lightweight alternative to heavy and iron concrete covers*



*Completed project with Fibrelite's heavy duty covers installed.*

## Fibrelite Supplies Replacement Composite Covers for German Tunnel Project



*Watertight FL60-D400 cover*



*Old access frames can easily be removed and replaced with Fibrelite frames*

Fibrelite's lightweight composite covers have been used to replace old concrete covers that had become unsafe, and unfit for purpose. The FL60-D400 covers were installed as a replacement to the previous concrete ones, ideal for its lightweight single person removal (with the FL7A), with 40 tonne load rating properties.

Fibrelite's composite covers are tested to BS EN 124 and are available with load ratings from A15 up to F900 depending on the application. The patented monolithic structure of a Fibrelite cover means that they will not crack or delaminate during usage. They are also chemically inert and have zero re-sale value to the scrap market, meaning Fibrelite composite covers are an increasingly popular choice over metal covers.

### Problem

The customer had old unsafe concrete covers that were heavy to lift and were also crumbling away. These covers ran along the side of a tunnel and had to be watertight if any water got into the tunnel.



*Old unsafe concrete covers*



*Hassle free and quick cover frame installation*



*Fibrelite covers will not rust and degrade like metal and concrete covers*





**WATER & WATER TREATMENT**

**FIBRELITE** 

**WE'VE GOT YOU COVERED**





Fibrelite provided a selection of lightweight covers

### Project Overview

JOD Engineering Services LTD approached Fibrelite looking for a lightweight covering solution to replace their existing heavy covers, the client supplies fresh water to millions of homes across the North West of England.

- Custom design to sit within existing frames
- Withstand heavy vehicle traffic – D400 load rated covers were required
- Lightweight alternative – most importantly, the client needed to upgrade the outdated heavy covers in favour of a modern lightweight alternative
- Easy to remove and replace – replacement covers should not require any heavy lifting equipment



Due to the weight and difficulty in removing the covers critical time is lost in emergency situations

### Problem

Ease of access to services below the trench was an issue due to the weight of the covers, making removal and replacement of the covers difficult and time consuming as specialist machinery was required.

- Quick and easy access to the underground water valves is essential for emergency repairs and monitoring when required
- To remove and replace the previous covers a crane was required, resulting in critical time being lost in emergency situations



The covers provided access to underground water valves

### Solution

Fibrelite designed and supplied custom trench covers to fit directly into the existing frames:

- The covers were manufactured and delivered to site within six weeks after an order to supply was received
- Best strength to weight ratio available in the market – our D400 load rated covers are lightweight yet extremely durable
- After removing the existing covers, the Fibrelite replacements fitted perfectly into the existing frames



## Results

The client is now able to gain access to the trench pits quickly and easily without the need for any specialist machinery:

- This was very important to the client due to their role as a fresh water supplier to millions in the North West of England
- Fibrelite trench covers can be removed and replaced by two-people using the ergonomically designed FL7 lifting handles
- Pre-existing manual handling health & safety issues were eliminated
- Fibrelite covers are both chemically inert and corrosion resistant

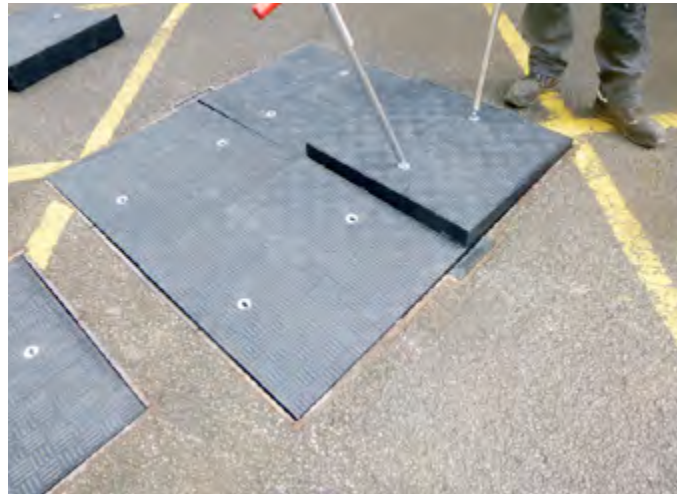

*The Fibrelite D400 load rated covers can be easily removed and replaced using the FL7 lifting handles*

## Fibrelite Provides Water Utility with Radio Frequency Compatible Composite Covers for Automatic Meter Reading Application



*This water company contacted Fibrelite about the possibility of installing automatic water meter readers in or beneath a composite cover*

### Project Overview

In 2017, in conjunction with an effort to automate their water meter collection services, this company contacted Fibrelite about the possibility of installing automatic water meter readers in or beneath a composite cover. The water company uses the SmartPoint 520M module (a Sensus product) to collect water meter usage data and transmit it to an aboveground receiver allowing for remote, real-time data collection (rather than collecting this information manually).



*Fibrelite composite cover molded with central recess, designed to embed RF antenna in top surface of the cover*

### Problem

For its larger water customers, this company uses SmartPoint 520M radio frequency (RF) transmitter modules that are typically installed in manholes or vaults that are covered by cast iron, steel or aluminum covers. Many of these manholes or vaults are located in roadways or areas that may be trafficked by a vehicle and therefore require a vehicle rated cover. The SmartPoint 520M transmits the meter data via an antenna that is mounted by drilling a hole in the cover and installing the antenna on the surface of the cover (as shown in the photo below). By placing the antenna on the top surface of the metal cover, the RF signals will not be blocked by the metallic cover. Unfortunately, this also exposes the antenna housing where it can be impacted by snowplow or lawn mower blades, vehicles and/or pedestrians.



*Previously installed metal covers exposed the antenna above the cover in order for the system to work*

### Solution

The water company contacted Fibrelite, who designed and manufactured a custom solution for them. Fibrelite's engineering team developed a solution that allowed the water company to embed the SmartPoint antenna in a recess molded into a 4" thick composite manhole cover. Mounting the antenna in the recess kept the antenna housing below the top surface of the cover and therefore safe from impact from snowplows, vehicles or equipment.

Fibrelite's composite access covers are lightweight, durable and very strong. Every Fibrelite cover is manufactured using high-technology, resin transfer molding production methods to create a highly engineered, monolithic composite product. Even with the 6" diameter molded antenna opening in the center of the cover, the Fibrelite manhole cover still allows for heavy vehicle trafficking across its surface.



## Results

Following a successful 6-month trial project during the winter of 2017-18, this water company will now be replacing several hundred existing manholes with Fibrelite's "embedded antenna" composite covers.



*The water company is now installing several hundred additional composite covers with antennas*

# Sewage Treatment Works, UK - Phase 1

## Heavy Cast Iron Replaced by Fibrelite's Lightweight Composite Covers

A wide range of Fibrelite covers have been specified for a sewage treatment works following plans for a refurbishment and modernisation of the site. What's more, this well-known water company were looking to combat the increasing problems with metal theft and the health and safety issues associated with the existing heavy and corroding cast iron covers.



Preparation work

With resin transfer moulded (RTM) composite having zero re-sale value to the scrap market, being lightweight for easy removal and easily achieving D400 load ratings where required, Fibrelite ticked all the boxes.



Ease of access: manholes that will soon have a new Fibrelite access cover

### Cost Competitive - Whole Life Cost

Composite covers have always been seen as a high cost alternative to traditional metal products. However, with Fibrelite's technological advances in the manufacturing process, the development of our B125 covers and rising metal prices, composite can now compete head to head with the likes of cast iron.

### Summary of Composite Benefits

- Composite is lightweight, durable and strong
- Specially designed lifting aid eliminates back injury and crushed fingers
- Non-metallic, non-conductive and will not spark
- Excellent insulator against heat
- Unaffected by underground gasses and most chemicals
- Incredibly strong monolithic structure that will not delaminate
- Treads incorporate a specialised anti-slip material equivalent to modern high grade road surface
- Range of UV stable colours available that will not flake or crack

### Easy and Safe Access

Once installed, Fibrelite's composite access covers are lightweight, durable and very strong.

Every Fibrelite cover is manufactured using high-technology RTM production methods to create a highly engineered, monolithic composite product.



Single FM45 ready for new concrete to be poured

**29 covers were specified in total.**

These Fibrelite covers are currently being installed. Rather than excavate, the covers will be sat directly on top of the manholes with a new layer of concrete shuttered on top of the existing up-stand.



## Sewage Treatment Works, UK - Phase 2

### Fibrelite Replace Heavy Duty Cast Iron Manhole Covers with Lightweight Composite Alternative



Fibrelite's lightweight 1.4m composite covers (type FL140) have recently been installed replacing heavy cast iron covers in a remote area targeted by metal thieves.

The newly installed FL140 C250 covers now provide safe and easy access to the underground piping and valves eliminating unsafe manual handling issues associated with removing large traditional cast iron alternatives.

In addition the load bearing, maintenance free composite covers have no resale value providing the perfect deterrent to metal thieves. Theft of manhole covers from remote or isolated areas is becoming a huge problem for all water companies costing the industry millions of pounds a year.



Fibrelite composite manhole covers



The 25 tonne load tested lightweight covers

With resin transfer moulded (RTM) composite having zero re-sale value to the scrap market, they are ideal fit and forget product in remote areas targeted by metal thieves

#### Customer Quote:

*"Using these covers eliminates manual handling issues and injury; the keys are at waist height so there's no need to bend down and the covers don't seize up so we don't need to bend down with extra tools to release them. And because they're so light, lifting is quicker which means we get more work done."*

#### Cost Competitive – Whole Life Cost

Composite covers have always been seen as a high cost alternative to traditional metal products. However, with Fibrelite's technological advances in the manufacturing process, the development of our B125 covers and rising metal prices, composite can now compete head to head with the likes of cast iron. Fibrelite has offices around the world with technical advice available at all times and working with the designers has ensured that the client has the right product for the application required.

#### Summary of Benefits

- Composite is lightweight, durable and strong
- Zero resale value to the scrap market so will not be stolen
- Specially designed lifting aid eliminates back injury and crushed fingers
- Non-metallic, non-conductive and will not spark
- Excellent insulator against heat
- Unaffected by underground gasses and most chemicals
- Incredibly strong monolithic structure that will not delaminate
- Treads incorporate a specialised anti-slip material equivalent to modern high grade road surface
- Range of UV stable colours available that will not flake or crack

## Fibrelite Supply Large Trench Cover Arrangement Over Specialist Storm Attenuation Tanks on a Residential Development



The Fibrelite B125 (12.5 tonne) load rated medium duty trench access covers installed

### Easy Access for Operators

As part of the current AMP5 programme, a flood alleviation scheme required Fibrelite's range of standard covers to be designed and manufactured for this complicated application. The main requirement being easy access for operators who regularly need to enter these chambers that control storm water in large underground tanks. The chamber itself is 3 metres wide by 13 metres long. The complexity of this application was designing the covers to sit over a fixed structural beam that runs down the middle of the chamber. In conjunction with the designers, contractors and end user, the trench cover arrangement was designed specifically in line with the brief. The location of the covers is a new housing development in Gwersyllt, North Wales. The covers, therefore, had to be safe for people walking across with the cover treads incorporating a specialised anti-slip material. For operators working at the site ease of access and safety are critical. Safety and the aesthetics of the covers in the location were key to the designers and public alike.



Fibrelite's treads incorporate a specialised anti-slip material for added safety

Fibrelite's lightweight bolt-down medium duty composite trench covers were identified as the solution. Designed as a 'fit and forget' product, the maintenance free covers provide easy and safe access to the essential equipment.



Designed to be in keeping with the surrounding area

### Modular Covering System Means Flexible Removal of Covers

Fibrelite's access covers are lightweight, durable and very strong. Every Fibrelite cover is manufactured using high technology resin transfer moulded (RTM) production methods to create a highly engineered, monolithic composite product.

The modular covering system provided means only the covers in a certain area need to be removed. To have a similar option in traditional material like metal or concrete would require large heavy covers that would require specialist lifting equipment or spring/gas assist covers. The Fibrelite covers are only a one or two man operation with the use of Fibrelite lifting handles.



Each Fibrelite cover installed at this site is lockable for added security

### Benefits of Fitting a Fibrelite

- Customised solutions
- A fit and forget product that will not corrode or fade
- Improved productivity for both operational and maintenance crews
- Improved health and safety practices
- Technical support



## Highly Effective in Preventing Heavy Lifting

Fibrelite's trench covers have proved highly effective in reducing health and safety issues and potential damage to essential pipework.

## No Compromise on Performance

Upon request, Fibrelite can provide bespoke and custom solutions. This means that the panel dimensions, internal stiffeners and fibre architecture can be altered to optimise the performance of each panel based on project specific design criteria.

## Sophisticated Highly Specialised Material

Fibrelite is the world leading manufacturer of glass reinforced plastic (GRP) composite manhole covers and trench covers. This sophisticated and highly specialised material is fast becoming recognised as the more effective modern alternative to traditional materials such as heavy steel and concrete.

Benefits over metal and concrete covers:

- Lightweight for easy and safe manual removal
- Load ratings from A15 to F900 (BS EN 124)
- Chemically inert and corrosion resistant
- Anti-slip/skid properties

## Fibrelite Supply Trench Cover Arrangements Over Waste Water Chambers



*The previously installed dangerous and corroded metal covers*

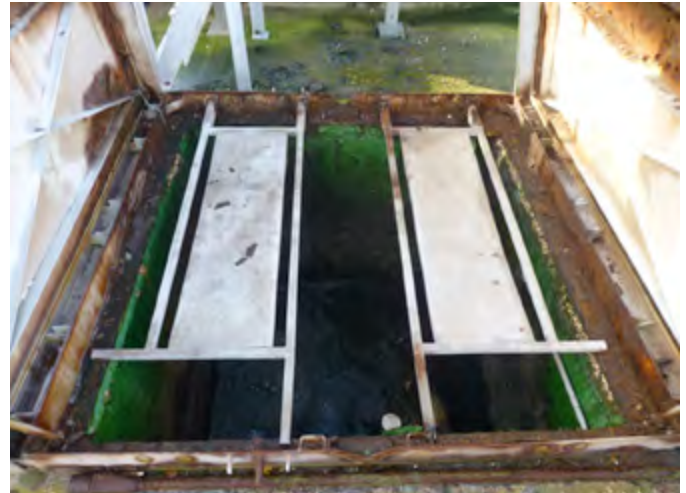

*The old heavy mechanical steel covers were replaced with the Fibrelite lightweight alternative*

### Fibrelite's Corrosion Resistant Covers

Due to the nature of the harmful methane gases, the previously installed steel covers were badly corroded and dangerous. By modifying the resin matrix Fibrelite was able to offer a chemical resistant cover. Fibrelite's composite covers are resistant to chemical and harmful gasses and are corrosion free. For these applications is the ideal replacement to conventional metal and concrete covers that can easily corrode and crack.

The modular cover design provided by Fibrelite offered single cover removal access where required. To have a similar option in traditional material like metal or concrete would require large heavy covers that would require specialist lifting equipment or spring / gas assist covers. The Fibrelite covers are only a one or two man operation with the use of special lifting handles.



*Specialised vent pipe could also be incorporated into the Fibrelite design*



*The Fibrelite A15 (1.5 tonne) load rated super light duty trench access covers*



## Easy Access for Operators

Fibrelite's range of super light duty covers were designed and manufactured for this complicated application. The main requirement was easy access for operators who regularly need to enter these chambers that contain waste water in large underground tanks. The chambers were of various sizes and tended to be concrete in construction. The ease of fitting the Fibrelite system meant the frames could be bolted directly on top of the chamber. This meant the costly job of breaking out and re-concreting in was not required.

## Sophisticated Highly Specialised Material

Fibrelite is the world leading manufacturer of glass reinforced plastic (GRP) glass reinforced plastic (GRP) composite manhole covers and trench covers. This sophisticated and highly specialised material is fast becoming recognised as the more effective modern alternative to traditional materials such as heavy steel and concrete.

Benefits over metal and concrete covers include:

- Lightweight for easy and safe manual removal
- Load ratings from A15 to F900 (BS EN 124)
- Chemically inert and corrosion resistant
- Anti-slip/skid properties

## Benefits of Fitting a Fibrelite

- Customised solutions
- A fit and forget product that will not corrode or fade
- Improved productivity for both operational and maintenance crews
- Improved health and safety practices
- Technical support

## Fibrelite Supply Custom Design Trench Covers for Leading UK Water Company

In conjunction with the designers, contractors and end user, the trench cover arrangement was designed specifically in line with the brief for this location in a busy waste treatment plant at Alfreton, Derbyshire. Therefore the covers had to be safe for people walking across with the cover treads incorporating a specialised anti-slip material. For operators working at the site ease of access and safety are critical.

Fibrelite's super light duty composite trench covers were identified as the solution. Designed as a 'fit and forget' product, the maintenance free covers provide easy and safe access to the essential equipment.

Fibrelite's access covers are lightweight, durable and very strong. Every Fibrelite cover is manufactured using high technology resin transfer moulded (RTM) production methods to create a highly engineered, monolithic composite product.

## Highly Effective in Preventing Injuries Lifting

Fibrelite's trench covers have proved highly effective in reducing health and safety issues and potential damage to essential pipework.

## No Compromise on Performance

Upon request, Fibrelite can provide bespoke and custom solutions. This means that the panel dimensions and fibre architecture can be altered to optimise the performance of each panel based on project specific design criteria.

## Covers for Remediation Wells, UK

### Fibrelite Supply 120 Orange Coloured Composite Covers for Remediation Wells

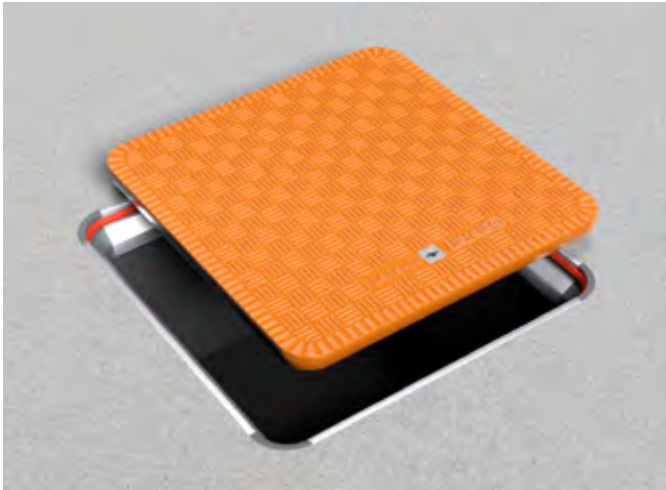

Fibrelite's popular FL60/C250 cover

### Coloured Covers for Easy Recognition

Fibrelite has been specified to provide watertight GRP composite access covers for over 120 remediation wells linked in hundreds of metres of trenches. Covers were either C250 (25 tonne) for standard traffic and D400 (40 tonne) for HGV loading areas.



Heavy duty Fibrelite FL60/D400's

### Lightweight, Watertight, Strong and... Orange!

These were only some of the required criteria for specifying Fibrelite:

- Lightweight for easy and safe manual handling during installation and during the regular removal and replacement.
- Watertight to ensure no dirt or water can ingress into the remediation wells.
- Strong: Despite the covers being lightweight it was important that they could withstand frequent heavy loads from HGV's and heavy plant. With Fibrelite covers ranging from 1.5- 90 tonne loadings this was not a problem.
- Orange: It was important that the covers could be easily seen in a dirty and sometimes hazardous environment.



The trenches before Fibrelite install

### No Need for Painting...

Fibrelite can provide covers in practically any colour with a RAL reference. Coloured pigment is added to resin that is then injected to the cover, so rather than painting the covers a completely integrated colour is achieved with the following benefits:

- Will not fade
- Will not flake or crack
- Never requires repainting
- Completely UV stable
- Will not be affected by dirt and debris



Fibrelite Solve Manual Handling Issues by Developing Composite Covers to Replace Heavy, Difficult to Remove, Concrete Covers



Lifting equipment required to remove heavy concrete covers



Time consuming and costly removal process

Fibrelite have recently developed a range of composite access covers to replace traditional heavy concrete infill covers. The range includes D400, E600 and F900 load ratings and have been designed to be installed into existing frames. This industry first means it is now possible to upgrade to modern composite materials simply and effectively without the costs and disruption associated with breaking concrete to replace with new frames.

### Lightweight and Strong – Safe Manual Handling

Traditional concrete covers are extremely difficult to remove to allow access, often requiring time consuming, expensive, specialist lifting equipment. This often leads to manual handling problems and possible risks to operatives trying to remove the covers. Fibrelite's new range of bespoke replacement composite covers offer the best strength to weight ratio in the industry. Whilst achieving BS EN124, D400, E600 and F900 load ratings their unique composite design means they can be easily removed using a simple ergonomically safe lifting handle.

### Bespoke Composite Covers for Retro Fitting

Composite materials are becoming increasingly popular across a range of industries and Fibrelite's composite covers now offer an innovative solution by eliminating common health and safety issues often associated with manual handling.

### Key Benefits to Fitting Fibrelite

- Lightweight for easy and safe manual removal
- Load ratings from A15 to F900 (BS EN 124)
- Designed to fit in existing frame
- No need to break concrete
- Quick convenient installation process
- Bespoke solutions available for complex projects



Bespoke Fibrelite covers installed into existing frame



Easy and safe manual handling with Fibrelite lifting handle

## Waste Water Plant, Antarctica

Fibrelite Supply Super Light Duty Trench Covers for Specialist Waste Water System to be Installed in the Antarctic

**FIBRELITE** 



*The specialist waste water treatment system at this plant*

### Fibrelite Supply Trench Covers for Specialist Waste Water Treatment System

This specialist piece of equipment that has been designed and manufactured for use in the Antarctic required lightweight covers for easy access. Fibrelite's range of standard trench covers was identified as the solution and became an integral part of the design.

The system is for treating black and grey waste water before discharging into the sea. This is all waste water from the installation including sewage, laundry and cooking etc. Working with the lead designer from the start we were able to manufacture the covers to fit the specific sizes required. In turn the designer was able to ensure the Fibrelite covers were an integral part of the design. In harsh conditions in the Antarctic ease of access was critical and the fact they were lightweight for people to use was another major benefit. With such extreme temperatures the benefit of GRP properties being non-corrosive and not affected by temperature variations was critical. The covers are lifted regularly to ensure the system is working efficiently. For operators working within the facility, ease of access and safety are critical



*The two systems were adapted for Fibrelite trench covers for access from above*



*Ready for the harsh conditions of the Antarctic*

### At the Forefront of Quality and Innovation

Fibrelite's range of standard and bespoke trench covers are available in a variety of load ratings, a wide selection of sizes to replace traditional cast iron or concrete versions. Designed as a 'fit and forget' product, the maintenance free covers provide easy and safe access to the essential equipment. Fibrelite's access covers are lightweight, durable and very strong. Every Fibrelite cover is manufactured using high technology resin transfer moulded (RTM) production methods to create a highly engineered, monolithic composite product.

### Sophisticated Highly Specialised Material

Fibrelite is the world leading manufacturer of glass reinforced plastic (GRP) composite manhole covers and trench covers. This sophisticated and highly specialised material is fast becoming recognised as the more effective modern alternative to traditional materials such as heavy steel and concrete.

Benefits over metal and concrete covers:

- Lightweight for easy and safe manual removal
- Load ratings from A15 to F900 (BS EN 124)
- Chemically inert and corrosion resistant
- Anti-slip/skid properties

### Highly Effective in Preventing Heavy Lifting

Fibrelite's trench covers have proved highly effective in reducing health and safety issues and potential damage to essential pipework.

### Benefits of Fitting a Fibrelite

- Customised solutions
- A fit and forget product that will not corrode or fade
- Improved productivity for both operational and maintenance crews
- Improved health and safety practices
- Technical support





*Fibrelite's fit and forget covers are corrosion-free, lasting for years to come*

### No Compromise on Performance

Upon request, Fibrelite can provide bespoke and custom solutions. This means that the panel dimensions, internal stiffeners and fibre architecture can be altered to optimise the performance of each panel based on project specific design criteria.

## Fibrelite Supply Lightweight Composite Trench Covers Over a Riverside Valve Chamber



Beautiful Lake District location



Lightweight Fibrelite trench covers now installed

Fibrelite Super Light Duty trench covers were recently chosen to replace cobbled covers over a valve chamber at Newby Bridge. The covers were installed to provide access to a chamber containing valves which control the flow out of the lake into the River Leven below.

### Key Benefits

- Quick and easy access due to light weight
- Bespoke cover sizes up to 1.8 metres long
- Non-slip surface
- Load ratings from A15 – F900 (BS EN124)
- Corrosion resistant and maintenance free

### Heavy Cobbled Covers Delay Urgent Work

The chamber, containing Penstock valves, is situated alongside a large weir within the boundary of the idyllic Lake District National Park. The Fibrelite covers replaced steel recessed covers with cobbled stone infill. These heavy covers could not be removed manually, requiring lifting equipment to gain access to the valve chamber. This time consuming and costly procedure also caused major problems in emergency situations, when immediate access to the valves is often required to regulate the flow of water out of the lake.



Cobbled covers requiring lifting equipment



Easy lift Fibrelite covers

### Easy, Quick and Safe Access with Lightweight Fibrelite Trench Covers

Fibrelite's Super Light Duty trench covers were identified as an obvious solution to this issue for their high strength, low weight and ease of manual handling. Fibrelite designed and manufactured lightweight, composite trench covers, which were supplied complete with an encapsulating aluminium frame and steel support beam. The light weight of Fibrelite composite covers, combined with the use of the FL7 lifting handle, ensures that these covers can now be easily and safely lifted manually. This allows operatives quick and easy access to the chamber as soon as required. The cover arrangement had to be designed to allow for removal of the actuator valve for future maintenance or replacement. Fibrelite achieved this by using a central removable support beam that gives complete access to the valve pit. Due to the riverside location, the area is prone to flooding. For this reason, Fibrelite supplied trench covers with restraining bolts to ensure these covers remain in the frame during flooding events.





*"Cassette" of bespoke covers over culvert*

### Project Overview

A major UK construction company required a covering solution for a newly constructed culvert. This was located close to a pedestrian walkway area so would have frequent pedestrian traffic. Due to the shape and dimensions, it required a "cassette" of bespoke covers and additional support beams.

### Problem

When Fibrelite was approached the culvert was already under construction. The challenge was to provide a bespoke "cassette" of specific shaped covers to fit the existing culvert along with the appropriate support beam structure within a limited time frame.



*Bespoke "cassette" of Fibrelite covers and supporting steelwork installed to tight construction deadline*

### Solution

The Fibrelite "cassette" was designed, engineered and installed to the specified time frame. The covers supplied were moulded to shape in the Fibrelite factory and supplied as a complete unit ready for installation.

The covers are maintenance free and suitable for a safe two-person manual lift employing the supplied ergonomically designed Fibrelite lifting handles, allowing lifting from waist level preventing back injuries. As the covers are located very close to a pedestrian walkway area the standard Fibrelite tread pattern provided the perfect slip resistance required.



*Standard Fibrelite tread pattern provides anti-slip for safe pedestrian traffic*



*Covers supplied moulded to shape in the Fibrelite factory and supplied as a complete unit ready for installation*



Maintenance free and no mechanical parts: Fibrelite's FM45 Composite Trench Panels



Fibrelite's specially designed lifting handle

### Dangerous Heavy Metal Covers with Failing Fall -Restraints

A combination of failing fall-restraints and cover segments weighing in excess of 70kg made the Health and Safety risks unacceptable for Severn Trent Water on this Combined Sewer Overflow (CSO) site. With RIDDOR statistics attributing over half of injuries (resulting in absence from work) to manual handling it's logical that reducing hazards in this area is a priority for UK water companies.

Following research into various alternatives, Severn Trent Water saw Fibrelite as the preferred partner to help eliminate on-site dangers associated with manhole and trench access.



Some of the Fall-restraints, gas assists and mechanical spring struts have been failing creating serious risk of injury to technicians

### No Mechanical Parts & Lightweight = Safe & Easy Manual Handling

With no need for hinges or mechanical parts there is no potential for failure and no requirement for ongoing maintenance- the Fibrelite FM45 is a 'fit and forget' product. What's more, with weight lifted not going beyond 25kg, Fibrelite's trench panels tick all the boxes in terms of Health and Safety. Mark Corbett Safety Coach for West Waste Water said: *Using these covers eliminates manual handling issues and injury; the keys are at waist height so there's no need to bend down and the covers don't seize up so we don't need to bend down with extra tools to release them. And because they're so light, lifting is quicker which means we get more work done.*



Safe and easy manual removal: Fibrelite FM45 covers are removed by hand from the CSOS (Combined Sewage Overflow System) chamber



## Fibrelite: First for Safety and Security

Severn Trent Water approached Fibrelite with problems relating to the security of manhole and trench access covers. For remote areas or anywhere there is a requirement for increased security various locking options and restraining methods are available from Fibrelite.

Everything from simple screws to a terrorist proof lock is an optional addition to a Fibrelite cover. In this instance, the below lock was used with a 'tork key' rather than allen key as a deterrent to unwanted access.

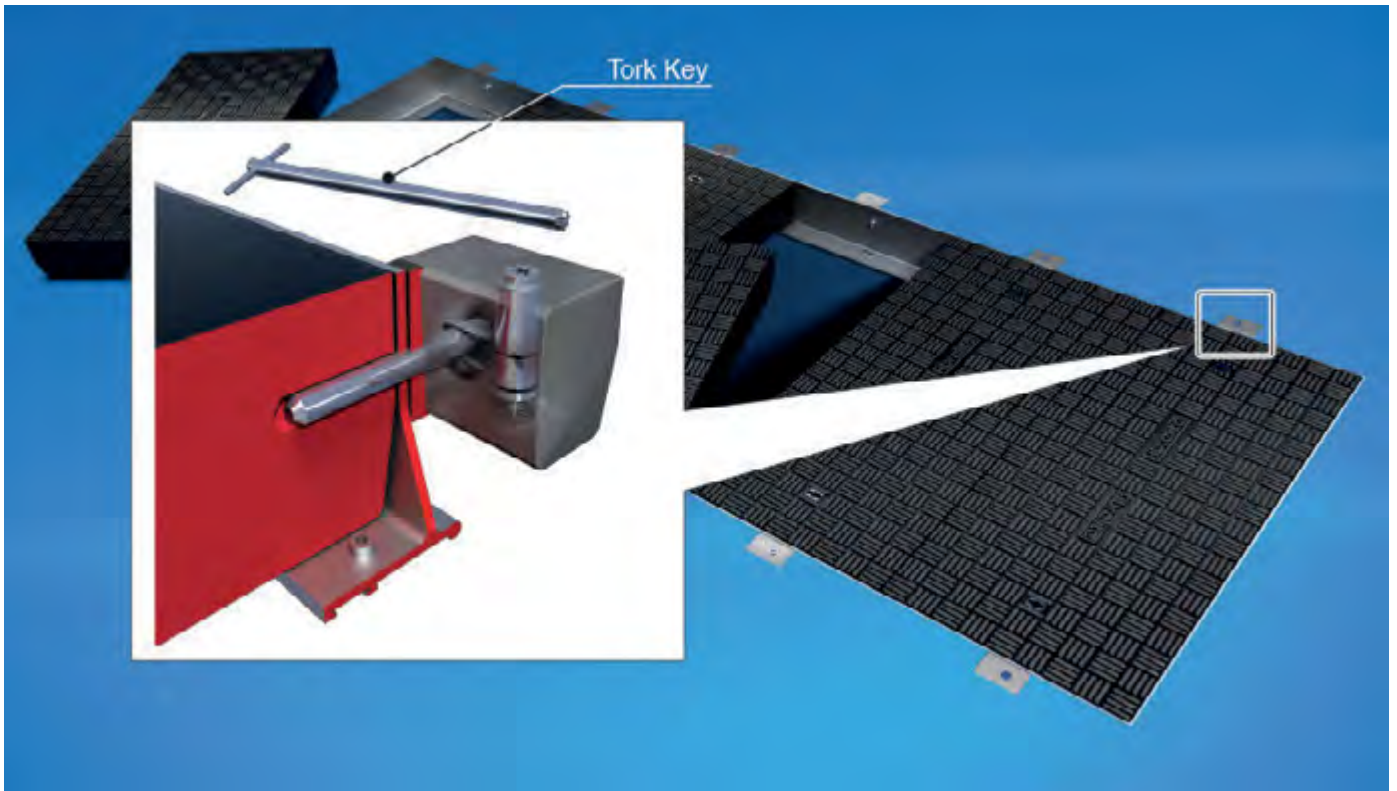

*Maintenance free and no mechanical parts: Fibrelite's FM45 composite trench panels*



*Fibrelite A15 (1.5 tonne) load rated lightweight trench access covers*

### Fibrelite Supply Trench Covers for Natural Spring at a School in Settle

Fibrelite's composite access covers offer easy access for operators who regularly need to access the chambers that house natural spring water to supply the school. Due to the nature of what is underground the covers need to be easy access for operators who regularly check and monitor the levels and quality of the water. The chambers are in a remote location where access to the site is difficult so ease of access and safety are critical.



*Fibrelite encapsulated frame*



*Chemically inert and corrosion resistant covers*

Fibrelite's access covers are lightweight, durable and very strong. Every Fibrelite cover is manufactured using high technology resin transfer moulded production methods to create a highly engineered, monolithic composite product.

### No Compromise on Performance

Upon request, Fibrelite can provide bespoke and custom solutions. This means that the panel dimensions, internal stiffeners and fibre architecture can be altered to optimise the performance of each panel based on project specific design criteria.



## Extremely Heavy Slate Tiles Replaced with Lightweight Composite Covers

Original slate tiles were covering the natural spring which caused a health and safety issue and needed replacing. Fibrelite's super light duty composite trench covers were identified as the solution. Designed as a 'fit and forget' product, the maintenance free covers provide easy and safe access to the chambers.



*Old heavy slate covers posed a lifting hazard when access was required*

### Highly Effective in Preventing Heavy Lifting

Fibrelite's trench covers have proved highly effective in reducing health and safety issues and potential damage to essential valve equipment.



*Heavy slate covers were replaced with Fibrelite's lightweight trench covers*

### Sophisticated Highly Specialised Material

Fibrelite is the world leading manufacturer of glass reinforced plastic (GRP) composite manhole covers and trench covers.

This sophisticated and highly specialised material is fast becoming recognised as the more effective modern alternative to traditional materials such as heavy steel and concrete. Benefits over metal and concrete covers:

- Lightweight for easy and safe manual removal
- Load ratings from A15 to F900 (BS EN 124)
- Chemically inert and corrosion resistant
- Anti-slip/skid properties

### Benefits of Fitting a Fibrelite

- Customised solutions
- A fit and forget product that will not corrode or fade
- Improved productivity for both operational and maintenance crews
- Improved health and safety practices
- Technical support



# Water Monitoring System, Cádiz, Spain



## Fibrelite Covers Solve RF Transmissions Issues for Automatic Water Monitoring System in Town of Cádiz



Town of Cádiz, Spain (Image credit: Solundir)

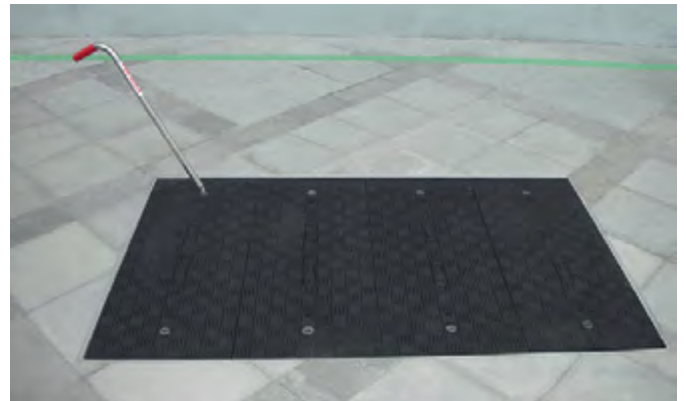

All Fibrelite trench covers can be safely manually lifted with the FL7 lifting handles (Image credit: Aguas de Cádiz)

### Project Overview

Municipal company Aguas de Cádiz and the University of Cádiz working together, completed a project allowing automatic monitoring of the drinking water network of the town. Electronic instrumentation consisting of a flow meter, pressure sensor and transmitter attached to pipework were installed underneath access covers in a number of locations through the town of Cádiz. These collected and sent data to the Aguas de Cádiz central office via GPRS.

### Problem

The purpose of the automatic monitoring system was not only able to have instant information about the consumption of water from each sector of the town but, to detect any leak of water in real time allowing repairing in a record time. However, the cast iron covers used as standard were obscuring or completely blocking the data transmission leaving the chamber, especially in pedestrian and highly trafficked areas.



Automatic monitoring system located beneath metal cover which blocked signal (Image credit: Aguas de Cádiz)

### Solution

Fibrelite trench covers were fitted into existing frames over each chamber, preventing expensive breakouts and time for concrete to set. Their composite covers provide no interference to signals, so allow electromagnetic (EMI) and radio frequency (RF) signals to pass directly through them, such as GPRS in this instance.



Fibrelite FM45 covers installed allowing RF signals to pass freely through (Image credit: Aguas de Cádiz)



Fibrelite trench covers fitted into existing frames, preventing expensive breakouts and time for concrete to set (Image credit: Aguas de Cádiz)





Underground water monitoring system (Image credit: Aguas de Cádiz)

## Results

Once Fibrelite's trench covers had been fitted on the chambers in May of 2014, clear transmissions of the GPRS signals were received at the Aguas de Cádiz central office from all installed locations, allowing for monitoring of water usage and leaks.

## Testimonial

The president of Aguas de Cádiz, Ignacio Romani, stated that:

*"with these [remote monitoring] systems Cádiz will be a principal pioneer in the remote management of the supply network of the city. This operation complements the continuing work that has been underway for years to renovate and modernize networks and sanitation of the city " And that "from the point of view of saving, this system is very important because it can detect leaks in the network enabling immediate action."* [Translated]

(Source: "Ayuntamiento De Cádiz - Actualidad Y Noticias De Cádiz | Aguas De Cádiz Instala Unos Dispositivos Electrónicos Para Controlar La Red De Abastecimiento ")

# Pumping Station, Netherlands

Fibrelite Covers Solve Odour and Maintenance Issues at Pumping Station in the Netherlands



Heavy metal covers requiring 2 men and a crowbar to remove, emanating odours

## Problem

Neighbours of a waste water pumping station in the Netherlands complained of unpleasant odours polluting the surrounding air. These were emanating from a pit, housing two large submersible pumps covered by a pair of thick hinged aluminium covers, bolted in the middle.

Despite the bolts the covers were not airtight, so a large plastic sheet covered in sand was spread out on top of the covers in an attempt to contain the odours. Maintenance access to the pump necessitated the removal of the sand barrier, plastic sheet and the aluminium access cover with a crowbar.



Supports can be easily removed to create full clear access



Removable centre beam supports covers

## Solution

The hinges were removed, and a custom-made aluminium frame installed tightly fitted into the existing one and sealed with a waterproof sealant. The frame included a removable centre beam to accommodate two Fibrelite trench covers, and four retractable supports (two per panel) to hold the safety grids. Both the supports and centre beam can easily be removed to create full clear access, and are secured by stainless steel fittings and cables to prevent them falling into the pit.

To contain the odour, a rubber seal was fitted to the frame and the covers secured with four stainless steel bolts to each cover. Plugs were provided for the key housings to complete the seal, and bolt heads covered.

All Fibrelite trench covers are light enough to be safely manually removed and replaced (**Test Reports**). This is done by one or two people using the FL7 ergonomic lifting handles, designed to ensure lifting weight stays under the HSE (UK Health and Safety Executive) advised for distance from the body.

The finished result was flush with the top of the cover, eliminating possible trip hazards.



Removable beams hold safety grid



## Results

The maintenance team Ton Bertrand and Job Robben of water company Aa & Maas, were very positive about the result. When they arrived for commissioning the site was completely odourless and far quieter than when the metal covers were installed, with the sound of the running water under the cover barely audible. They also showed enthusiasm at the ease of removal and replacement of the covers, and interest in rolling out onto further sites.



Sealed odour-tight covers installed

### Piet Bus from our partner TSE in Holland said:

*“Thanks to the ability of Fibrelite to produce panels that exactly met the dimensional requirements we were able to solve the problem the client was facing. Besides the perfect dimensions Fibrelite provided the panels with locking bolts at specified spots to hold the panels in place in case of over-pressure in the pit. The bolts are protected from dirt by rubber plugs.”*



Bolts to seal covers, covered with rubber plugs

# Water Treatment Facility, Florida, USA



## Concrete to Composite: Florida Based Water Treatment Facility Turns to Fibrelite for Composite Trench Access Panels



Concrete to Composites

### Advanced Design – Bigger Advantages

Fibrelite is the world leading manufacturer of Fibreglass Reinforced Plastic (GRP) composite manhole covers and trench panels. This sophisticated and highly specialised material is fast becoming recognized as the more effective modern alternative to traditional materials such as heavy steel and concrete.

Though metal covers were considered as a replacement, the following benefits meant Fibrelite's GRP composite covers were chosen:

- Lightweight for easy and safe manual removal
- Non-slip properties equivalent to a high grade road
- Chemically inert & corrosion resistant
- Extremely strong and durable



Lightweight composite trench covers

A large water treatment plant on the Atlantic coast of Florida has replaced their aging, concrete trench panels with a series of Fibrelite's lightweight, composite alternatives. The facility, which produces approximately 30 million gallons of drinking water per day, requires access to service pipe work on a regular basis for maintenance and repairs. The large concrete panels they had in place, common within the water treatment industry, were not only difficult and dangerous to remove but had also degraded and crumbled over time.



Traditional concrete panels are unsafe and labor intensive to remove and often break apart over time

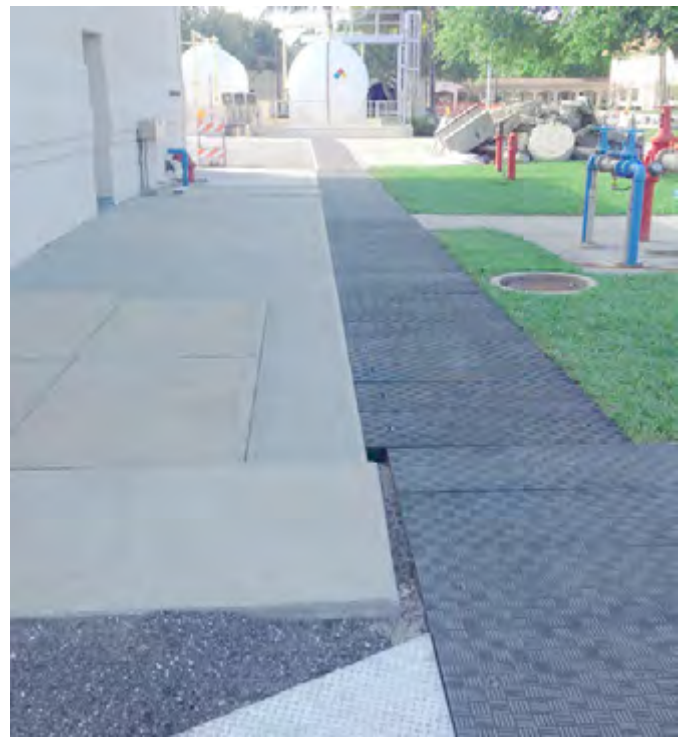

Perfect alternative to concrete





**PUBLIC AREAS**

**FIBRELITE** 

**WE'VE GOT YOU COVERED**



Fibrelite Upgrades Previously Installed Concrete Covers to Bespoke Lightweight Alternative



Fibrelite provided a bespoke, securable, maintenance-free access solution for RJ Utility Services

**Project Overview**

Fibrelite was approached by RJ Utilities Ltd to provide a safe, long-term replacement for old, failing concrete trench covers which covered essential underground utilities. For this project, ease of access, customisability and safety were of the highest importance.



RJ Utilities required trench covers that would improve the efficiency and safety of the site

**Problem**

Previously, heavy concrete trench covers had been fitted over below ground utilities and equipment. Due to their weight, the covers were extremely difficult to remove and replace safely, causing manual handling risks for operators. The equipment beneath the trench covers also posed a hazard to the public as the covers did not have a secure locking system. Inadequate security in the form of wooden fencing surrounding the perimeter further highlighted the need for modernisation.

In addition, the concrete covers had begun to break apart, potentially leading to a substantial risk to the underground valve and piping system. The obtrusive framework (pictured below) led to further difficulties and health and safety risks for engineers accessing equipment in the trench.



The previously installed obtrusive framework made access difficult and led to health and safety risks

**Solution**

Fibrelite designed and manufactured bespoke super lightweight (A15 load rated) composite trench covers to offer easy access to the entire trench, improving efficiency and safety.

The new covers and frame allows for quick and easy access for people working onsite as the trench is no longer divided into separate sections. Fibrelite covers are corrosion-free, lightweight and durable, and can be safely removed and replaced by two people using the ergonomically designed FL7 lifting handle, preventing manual handling injuries by lifting from the waist. The provided trench covers were lockable for added security, preventing unauthorised access.



Fibrelite super lightweight covers grant immediate, authorised and safe manual access with no specialist equipment required





*These bespoke trench covers were custom designed to offer easy access to the entire trench*

**Results**

The site now has a securable, aesthetically pleasing and maintenance-free access solution. Previous manual handling and safety concerns have been eliminated as onsite staff no longer put themselves in harm's way by lifting heavy concrete covers and navigating around the hazardous framework which had previously been installed.



*Fibrelite provided a long-term composite access solution tailored to the exact requirements of the customer*

# Hammersmith Flyover Bearing Pits, London, UK



Fibrelite Trench Covers Provide an Engineered Covering Solution Over Bearing Pits for Iconic Hammersmith Flyover in London



London Hammersmith flyover during refurbishment



Bespoke composite trench covers designed with encapsulating frames

## Project Overview

As part of the essential refurbishment and strengthening of this iconic London flyover, roller bearings at the base of the supporting piers were replaced due to wear, corrosion and the ever increasing vehicular traffic volume. The replacement spherical sliding bearings are located in underground bearing pits, which are now covered by an encapsulating row of bespoke GRP trench covers. The cover design layout accommodates minor movement of the pier.

## What Was the Problem?

The previously installed concrete recess covers were cumbersome, preventing easy inspection and maintenance access to the bearing pits. They also exhibited major fatigue. A solution was required in specific sizes with a securing mechanism to prevent unauthorised removal of the covers, while allowing easy access when essential maintenance was required. As the covers would potentially experience both pedestrian foot traffic and the occasional vehicular wheel the covers had to be designed for both environments.

## What Was the Fibrelite Solution?

Fibrelite worked in close collaboration with the designing engineers (Ramboll) and the installation contractor (Pro Steel) to design, manufacture and deliver a custom made covering solution for the 15 piers, totalling 500 individual GRP trench covers encapsulated within a purpose designed frame. The bespoke GRP trench covers were equipped with locking device to prevent unauthorised access.

Handling pedestrian and vehicle traffic was achieved by supplying a C250 (25 tonne) load rated cover with a unique anti-slip/skid tread pattern surface.



Lightweight tailor made Fibrelite covers set into frame around supporting pier

## Results

Fibrelite's GRP composite access covers have an inherent resistance to corrosion, offering a maintenance free 'fit-and-forget' solution. This means when you fit Fibrelites, they will continue to perform over time and retain their snug fit, minimising water ingress. When essential maintenance is required, the lightweight trench covers can quickly, safely and easily be removed using the custom 'key' and Fibrelite's ergonomically designed lifting handles. Fibrelite's GRP covers also have anti-slip properties equivalent to a modern high grade road surface whether wet or dry, far exceeding health and safety advisory limits [independent test reports] providing a safe walking surface. All Fibrelite access covers are BS EN 124 load test compliant, meaning consistent high quality is assured.





*Roller bearings at bases of supporting piers before being replaced*

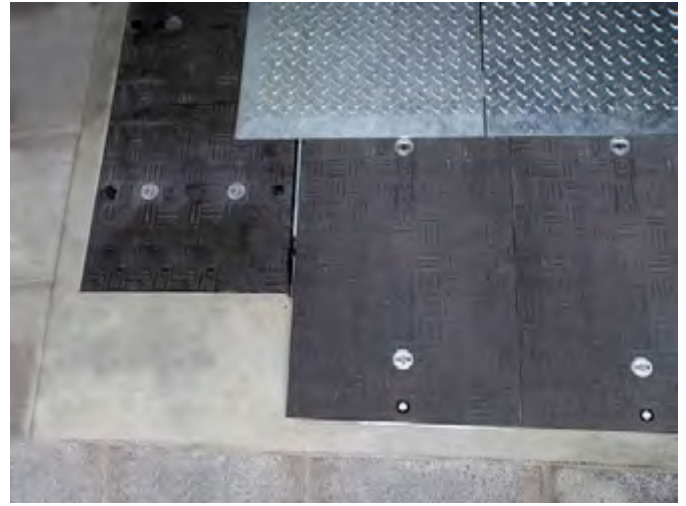

*Securing system moulded into covers which locks into frame, preventing unauthorised access*



*Replacement bearings located in the underground pits, covered by continuous set of access covers, allowing for the minor movement of the pier*



*Spherical sliding bearings located in underground pits, allowing for minor movement of the pier*



*Roller bearings at the bases of supporting piers were replaced due to wear and increased load on the bridge*

# Duke University, North Carolina, USA

Fibrelite Design and Manufacture Custom Covers and Frames for US University



Duke University install Fibrelite trench covers

## Project Overview

Duke University approached Fibrelite looking for trench covers to protect and prevent unauthorised access to power cables whilst being safe and easy to remove and replace.

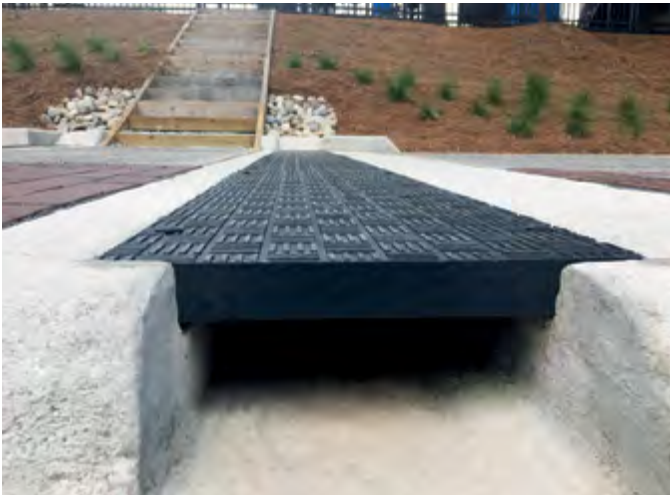

Lightweight Fibrelite trench covers allow easy safe manual removal

## Problem

The trenches contained cables which ran from the power station at the top of the hill down to access points for vehicles including media trucks and vans, meaning that safe and easy access was essential. Bolted covers which had a non-slip surface were vital as they were in a public place used by pedestrians and joggers.



Covers can be safely and quickly removed by two people using the FL7 lifting handle

## Solution

Fibrelite designed and manufactured bolted trench covers and frames to fit directly into the new location and prevent unauthorised access. Due to Fibrelite covers' unrivalled strength to weight ratio, all trench covers can be safely and quickly removed by two people using the FL7 lifting handle. This ensures safe lifting from waist height, eliminating pinch points and potential back injuries.



Bolted trench covers and frames to fit directly into the new location

## Results

Duke University has a lightweight covering solution which can be safely and quickly removed without the need for lifting equipment, eliminating any risk of injury and increasing efficiency.



# Fire Water Tanks, California, USA



California Business Development Chooses Fibrelite's Covers for Easy Access to Fire Water Tanks in Case of Emergency



Fire protection tanks

A California business development required easy and quick access to their fire water manway tanks in case of emergency. They chose Fibrelite's H20 rated trench lids which can be manually lifted so heavy machinery is not required. Fire protection tanks are water storage tanks specifically designed and used for commercial, industrial, residential, and institutional building's fire protection systems.

## High Loads for Heavy Traffic

An exclusive aluminum frame was used to install Fibrelite H20 trench lids. An H20 load rating was necessary since the panels are located on a sidewalk where heavy traffic regularly occurs. The frame was set higher than the sidewalk to create a slight slope in case of traffic exposure. Once the slope was created, the concrete-dried panels were installed and the maintenance department accessed the tank to check water levels and fill and disperse water as needed.



Fire manway lids (tank buried underneath)



Completed installation

## The Benefits of Using Fibrelite's Composite Access Covers

- Lightweight reducing lifting and handling issues: the trench covers are easily removed by a two person lift
- Custom covers are available: designed to retrofit into existing frame, which prevents breaking concrete and substantially reduces installation costs
- Improved efficiency and productivity: quick removal and no expensive and time consuming lifting apparatus required
- Corrosion and chemical resistant: compatible to harsh industrial environments
- Customised designs: available in different colours which will not fade with custom logos
- Composite is lightweight: strong and unlike concrete will not crumble or crack



Lightweight composite trench covers



*Financial Centre Singapore*

Fibrelite was the very first company in the world to design an easily removable composite manhole cover for the retail petroleum sector. The watertight properties are a necessity for oil companies as they strive to eliminate all risks of fuel contamination at service stations. After thirty years, Fibrelite remains number one in the market, supplying innovative new designs and has expanded its range of products to meet the technical requirements of other sectors, industries and applications.

Due to the recent increase in metal theft (including manhole, gully and trench covers) which has reached epidemic proportions in some countries, there is a significant demand for a fibreglass solution to the problem.

One of Japan's largest general contractors, a global leader in civil engineering, construction and development projects has specified Fibrelite's lightweight non-corrosive composite access covers for a new financial centre development in Singapore.

The contractor has specified Fibrelite's composite covers to be used for their customer's site at the newly built financial centre. Fibrelite's composite access covers were specifically chosen for this development as a totally watertight solution was required.



*Fibrelites composite manhole cover - FL76*



## Electric Provider, Edmonton, Canada

A Leading Canadian Electric Company Chooses Fibrelite's Heavy Duty Trench Covers to Avoid Corrosion in Cold Weather Climate



*Finished cover installation in Edmonton*



*Fibrelite trench cover installations are simple*

A leading electric provider in Edmonton, Canada has recently turned to Fibrelite for the replacement of metal trench covers on a heavy foot traffic area. The covers provide access to vaults which house electrical switch gear that allows the electric company to switch from a customer's primary service to secondary service. The company decided to seek an alternative to their existing covers due to rust and corrosion problems resulting from water, ice, and road salt. Traditional metal trench panels can corrode over time particularly in areas where water and ice are prevalent for long periods of time.



*Composite trench covers provide better protection against harsh weather elements year-round*

### Fibrelite Can Customise!

The replacement covers that Fibrelite supplied were load rated for 40 tons (96,000 pounds) and coloured gray to match the sidewalk. Because the location of the access covers are in areas of use, the electric company specified that the covers must be secured so Fibrelite provided a locking feature in order to ensure that the covers stay secured to their frame. These covers can be easily and safely removed by using two Fibrelite lifting handles. Fibrelite's lightweight composite trench covers can be used for a multitude of applications: electrical utilities, airports, dockyards, and industrial facilities to name just a few.

### The Benefits of Using Fibrelite's Composite Access Covers

- Lightweight reducing lifting and handling issues: the covers are easily removed by a two person lift
- Custom covers are available: designed to retrofit into existing frame, which prevents breaking concrete and substantially reduces installation costs
- Improved efficiency and productivity: quick removal and no expensive and time consuming lifting apparatus required
- Corrosion and chemical resistant: compatible to harsh industrial environments
- Customised designs: available in different colour which will not fade with custom logos
- Composite is lightweight: strong and unlike concrete will not crumble or crack

### Fibrelite Replace 33 Metres of Concrete Trench Panels Providing Safe and Easy Access to Underground Heating Pipes

Fibrelite's lightweight anti-slip composite FM45 trench panels have recently been specified to replace over 33 metres of crumbling, hard to remove concrete panels. The newly installed FM45's now provide easy and safe access to the underground heating pipework, running from the hospital building to the boiler rooms.

#### Crumbling, Unsightly, Trip Hazard Concrete



*The previously installed run of concrete trench covers*



*Removed crumbling concrete cover showing heating pipes underneath*

#### Most Cost-Effective Composite Trench Panels

Following significant investment in new tooling the new A15 load rated 50mm depth trench panels are available in sizes from 800mm to 1600mm long. Fibrelite has successfully adapted the existing manufacturing process to utilise recycled glass fibres reducing waste and carbon emissions.

This eco-friendly manufacturing process means Fibrelite is now able to produce the most cost-effective trench panel to date resulting in significant cost benefits to customers throughout the construction industry.

Designed as a 'fit and forget' product for civil engineering situations the maintenance free FM45 is perfect for covering large areas, gullies, trenches and ducts where occasional or frequent access may be required.



*The same stretch following Fibrelite install*



Fibrelite replaced the old unsightly, trip hazard concrete with 74 trench panels of varying load ratings and sizes:

- 52 FM45C250-140 trench panels (1400 x 450 x 117mm)
- 15 FM45B125-140 trench panels (1400 x 450 x 117mm)
- 7 FM45B125-120 trench panels (1200 x 450 x 50mm)

The FM45B125-120 A15 load rated trench panels were Fibrelite's very first installation of the newly designed shallow trench panels (50mm depth). Responding to the customers' requirements the process took only four weeks from conception to delivery of this brand new product, including design, re-tooling and testing.



No slips or trips... The Fibrelite tread pattern which offers anti-slip qualities equivalent to a high grade road

## Fibrelite's FL7 Easy Lifting Aid

Proven to be ergonomically safe to remove and replace, the design incorporates two lifting points for the specially designed FL7 lifting aids. These allow the operators to remove the cover without trapping fingers or bending over thus maximising the safety of the lifting technique. The weight is kept close to the body preventing back injury: one of the main causes of absence from work and personal injury claims. The maximum weight of the largest panel is 25kg.

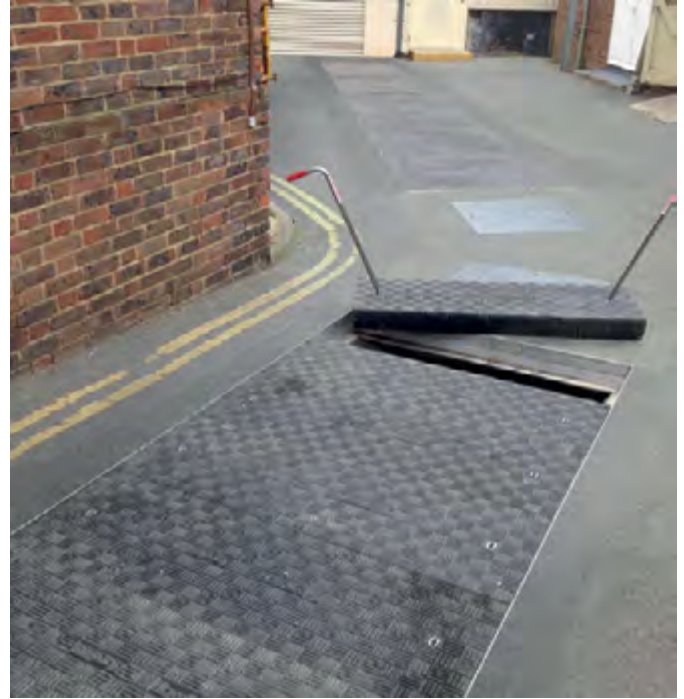

Safe and easy removal: FM45 removed using FL7s

## Customer Comments

*"The existing service pipe duct carrying heating pipes to the Hospital building from the boiler house were of the cast concrete interlocking type. They were difficult to remove for maintenance or in the event of a pipe failure in the duct."*

*"The new Fibrelite ducts make access problems a thing of the past. They are both easy to lift and look good as well."*



*Metal covers causing a trip hazard for pedestrians*

A major Malaysian utility company contacted Fibrelite Asia for advice on a specific set of issues it was experiencing with an existing installation.

The brief was to offer a retrofit covering solution that provided safe and easy access to the underground water valve that required regular access for maintenance, whilst at the same time eliminating the existing pedestrian trip hazard due to the open grating used. The company were concerned about the potential manual handling issues that their employees could experience along with the potential hazards to the general public when using open grating in a highly pedestrian trafficked sidewalk



*Costly cover removal*

The location of the installation, which was in the sidewalk of a high profile area of the city within immediate access of a large shopping and entertainment complex, meant that the replacement covering solution had to negate the need to break out the surrounding area.



*Bespoke Fibrelite trench covers*



*Lightweight GRP composite trench covers*

Fibrelite supplied a bespoke encapsulating frame that fitted directly into the existing rebate along with the Fibrelite 1.5 tonne load rated trench cover for the pit arrangement. The installation was extremely challenging due to the limited time available. Once the existing grating was removed the sidewalk needed to be re-opened within a few hours. To overcome the time constraints a bespoke epoxy grouting system was used to install the covering system.

Not only did the Fibrelite provide a retrofit light weight trench cover arrangement that complies with manual handling requirements for safe and easy access the covers also provide unparalleled anti-slip/skid properties for a composite cover due to the anti-slip material within the top treaded surface of the covers



## No Compromise on Performance

Upon request, Fibrelite can provide bespoke and custom solutions. This means that the panel dimensions, internal stiffeners and fibre architecture can be altered to optimise the performance of each panel based on project specific design criteria.

### Benefits of Fitting a Fibrelite

- Customised solutions
- A fit and forget product that will not corrode or fade
- Improved productivity for both operational and maintenance crews
- Improved health and safety practices
- Technical support

## Sophisticated Highly Specialised Material

Fibrelite is the world leading manufacturer of Glass Reinforced Plastic (GRP) composite manhole covers and trench covers. This sophisticated and highly specialised material is fast becoming recognised as the more effective modern alternative to traditional materials such as heavy steel and concrete.

Benefits over the more traditional, technologically inferior metal covers:

- Lightweight for easy and safe manual removal
- Load ratings from A15 to F900 (BS EN 124)
- Chemically inert and corrosion resistant
- Anti –slip/skid properties







**STEAM VAULTS**

**FIBRELITE** 

**WE'VE GOT YOU COVERED**



## Fibrelite's Steam Rated Covers Protect Against Heat for US University



Indiana University required steam rated manhole covers



The adverse conditions of the steam vaults had caused the locking mechanisms to fail

### Project Overview

Indiana University approached Fibrelite looking for steam rated manhole covers for new vaults and in replacement of existing covers on the Bloomington campus. The covers protect vaults that provide steam through two miles of tunnels across the campus.

### Problem

The previously installed metal covers made access difficult, the adverse conditions of steam vaults had caused the locking mechanisms to fail. The covers would heat up due to the steam vaults below, creating a health and safety hazard and putting the students and maintenance staff at risk of burning themselves.



The previously installed cover had made access to the vault difficult

### Solution

Fibrelite provided lightweight retrofit manhole covers which were heat resistant, eliminating potential health and safety risks. Fibrelite's lockable covers can be removed and replaced using the FL7 lifting handle, preventing the need for heavy lifting equipment to remove and replace the covers. This was important on this project as regular access was required.



The previously installed covers locking mechanism had failed due to the heat



Fibrelite's heat resistant covers provide safe and easy access to vaults





*Fibrelite cool-to-touch covers prevent dangerous heat transfer to the surface*



*No slips or trips... The Fibrelite tread pattern offers anti-slip qualities equivalent to a high grade road surface.*

## **Results**

Fibrelite's heat resistant covers provided Indiana University with a reliable solution enabling safe and easy access to vaults, the customer is now planning to replace other metal covers and install many more Fibrelite covers across campus to reduce health and safety risks for students and maintenance staff.

# District Energy Provider, Boston, USA



## Fibrelite Work with District Energy Provider to Replace Aluminum Steam Vault Covers in Busy Pedestrian Area

As part of a refurbishment program to replace/re-lag steam lines in Minneapolis a leading district energy provider has chosen Fibrelite's GRP composite steam trench panels to replace aluminum vault covers in the sidewalk.

Aluminum steam vault covers will conduct nearly all of the heat to the surface of the cover resulting in potentially dangerous conditions.



Previously installed aluminum covers - known for conducting heat to the surface

District energy networks provide customers located within a central city district with heating and cooling services. Steam lines are used to provide heat to apartments, retail stores and office buildings and can give off excess heat and steam thereby creating hot conditions in the steam vault above the steam line. In an effort to reduce heat transfer aluminum and other metal covers are often insulated on the underside



Degraded thermal insulation beneath the old aluminum vault covers

### Lightweight for Easy and Safe Manual Removal, Without Compromising on Strength

Fibrelite's composite GRP trench access covers are proven to be ergonomically safe for men and women to remove and replace and are perfect for access to steam vaults, electrical ducts and underground pipework.



Six Fibrelite FM45 4' 6" (1.6m) wide anti-slip GRP composite trench panels being installed in the sidewalk

### Fibrelite's GRP Composite Trench Panels - Cool to Touch!

Fibrelite's GRP trench panels exceed DOT H20 and H25 even when subjected to temperatures up to 400°F and are available in different load ratings. The thermal gradient properties of Fibrelite's GRP composite trench panels significantly reduce the heat transfer from a steam vault to the surface of the trench panel. Typically, the surface temperature of the panel will be slightly above the ambient temperature at street level even when subjected to extremely hot temperatures on the underside of the trench panel.



No slips or trips... The Fibrelite tread pattern offers anti-slip qualities equivalent to a high grade road surface.



## District Energy Network Chooses Fibrelite's Composite Steam Manhole Covers

A leading owner/operator of district energy networks in the US has chosen Fibrelite's composite steam covers to replace cast iron manhole covers in the sidewalk.

Cast iron steam covers will conduct nearly all of the heat to the surface of the manhole cover resulting in potentially dangerous conditions.

District energy networks provide customers located within a central city district with heating and cooling services. Steam lines used to provide heat to apartments, retail stores and office buildings can give off excess heat and steam thereby creating a hot condition below a manhole cover located above the steam line.



Hot manhole cover on sidewalk poses a threat to pedestrians



Fibrelite composite frame installed in sidewalk

## How to Eliminate the Hazards - Install Fibrelite Covers!

The hazards of hot manhole covers can be eliminated with Fibrelite's line of composite steam manhole covers. The thermal gradient properties of Fibrelite's composite covers significantly reduce the heat transfer from a steam vault to the surface of the cover. Typically, the surface temperature of the cover will be slightly above the ambient temperature at street level even when subjected to extremely hot temperatures on the underside of the cover.

Fibrelite covers have been third-party tested to handle loads exceeding DOT H20 load ratings even when subjected to temperatures of up to 400°F.



Fibrelite F95 composite cover installed in frame



Fibrelite F95 composite cover installed in frame

## University in Florida Uses Fibrelite's Steam Covers to Eliminate Safety Hazards Near Stadium



Public University, Gainesville, FL

A top state university in Gainesville, Florida, has recently turned to Fibrelite for the replacement of 24" steam manhole covers on campus. The university had decided to seek an alternative to their existing covers due to their concerns regarding public and staff safety. Traditional, cast iron steam manhole covers can reach extremely high surface temperatures due to the conduction of heat from within the manhole. Furthermore, removal of heavy, cast iron covers often puts the operator at risk of back and shoulder injuries.

Initially the university decided to replace two manhole covers that were located near their football stadium to eliminate the hazards presented by hot steam manhole covers.



Previously installed large cast iron covers were very heavy and extremely hot when exposed to steam within the manhole

### Fibrelite's Composite Manhole Covers - Cool to Touch!

The thermal gradient properties of Fibrelite's composite steam covers significantly reduce the heat transfer from a steam vault to the surface of the cover. Typically, the surface temperature of the cover will be slightly above the ambient temperature at street level even when subjected to extremely hot temperatures on the underside. Fibrelite's composite access covers have been tested to temperatures up to 400°F while still maintaining their "cool to touch" properties and ability to support vehicular loads.



Fibrelite installations are simple – a fiberglass skirt can be used as a preform and to set the frame at grade



New Fibrelite covers offer a "cool to touch" alternative to cast iron manholes in heavy foot traffic areas.

Since installing Fibrelite steam covers, the university has experienced significant reductions in heat transfer from the vault to the manhole surface. Further installations across the campus have now been scheduled as part of a replacement program for numerous 24" steam covers.





Original cast iron covers at the University were blocked because of their high temperatures due to steam.

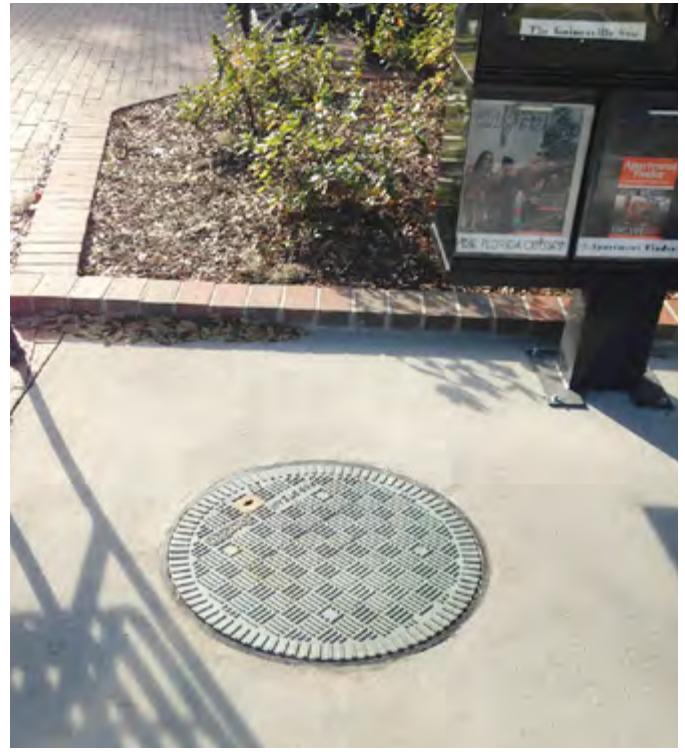

Lightweight composite steam cover - product code F65

## Historic University in the Heart of Connecticut Replaces Heavy, Aging Steel Manhole Covers with Fibrelite's Lightweight Alternatives



Public Liberal Arts University, Willimantic, CT

One of the oldest universities in Connecticut has recently begun a replacement program for their existing utilities manhole covers. The university turned to Fibrelite to provide a solution that eliminated the occupational injury risks associated with the removal of heavy, cast iron manhole covers. With a number of underground utilities all being maintained by staff at the university, Fibrelite needed to provide a range of products that were suitable for use above high temperature water vaults, sewer lines and electrical pits. These requirements were highlighted as follows:

- High temperature water – covers need to be thermally insulating to reduce burn risks
- Sewer – covers must provide odor control and prevent gas leaks without corroding
- Electrical – covers should be non-conductive to eliminate electrocution risk

Furthermore, Fibrelite's solution had to ensure that access into the manholes was impossible without the correct equipment. As a trial the university decided to initially replace one of their high temperature water covers in a green area. This cover was both extremely heavy and prone to heating up with increases in the vault temperature.



Heavy cast iron covers pose a significant threat of back & shoulder injuries along with the risk of trapped extremities



The newly installed Fibrelite 30" steam cover will significantly reduce the heat transfer from the vault to the manhole surface. The lightweight cover can now be removed by a single member of the Facilities team safely and easily using a specially designed lifting handle, thereby avoiding back strain injuries and trapped fingers.

### Fibrelite's Composite Manhole Covers - Cool to Touch!

The thermal gradient properties of Fibrelite's composite steam covers significantly reduce the heat transfer from a steam or high temperature water vault to the surface of the cover. Typically, the surface temperature of the cover will be slightly above the ambient temperature at street level even when subjected to extremely hot temperatures on the underside. Fibrelite's composite access covers have been tested to temperatures up to 400°F while still maintaining their "cool to touch" properties and ability to support vehicular loads.

### A Comprehensive Solution for Any Utility

Ideal for access to sewage systems, underground pipework, drainage networks, electrical junction boxes and telecommunications hardware, Fibrelite's standard utilities covers are non-metallic, corrosion-resistant and non-conductive. All Fibrelite manhole covers are fitted with a silicone gasket creating a watertight seal that protects the inside of the vault while also preventing the release of odors and gasses. In addition, suction created by this gasket makes the removal of the cover, without the correct lifting handle, practically impossible. With sizes ranging from 12" to 40", Fibrelite are able to provide covers for almost any application.



Fibrelite lightweight composite cover



# Leading University, Cambridge, USA



Prestigious University in the Boston Area Choose Fibrelite's Lockable Steam Covers to Eliminate Safety Hazards



World class university, Cambridge, MA

A top ranking university in Cambridge, MA, has recently turned to Fibrelite for the replacement of steam manhole covers within the Business School campus. The university, which is built on a large steam distribution network, had decided to seek an alternative to their existing covers due to their concerns regarding public and staff safety. Traditional, cast iron steam manhole covers can reach extremely high surface temperatures due to the conduction of heat from within the manhole. Furthermore, removal of heavy, cast iron covers often puts the operator at risk of back and shoulder injuries.

Initially the university decided to replace the two manhole covers that were located outside the campus daycare center to eliminate the hazards presented by hot steam manhole covers.



Large cast iron covers are both very heavy and extremely hot when exposed to steam within the manhole

## Fibrelite's Composite Manhole Covers - Cool to Touch!

The thermal gradient properties of Fibrelite's composite steam covers significantly reduce the heat transfer from a steam vault to the surface of the cover. Typically, the surface temperature of the cover will be slightly above the ambient temperature at street level even when subjected to extremely hot temperatures on the underside. Fibrelite's composite access covers have been tested to temperatures up to 400°F while still maintaining their "cool to touch" properties and ability to support vehicular loads.



Fibrelite installations are simple – a fiberglass skirt can be used as a preform and to set the frame at grade

High steam pressure within the manholes, often caused by flooding of the vaults, meant that the covers needed to be fixed in the frame to prevent displacement. Fibrelite's tamper-proof lock system provided a perfect solution for this.

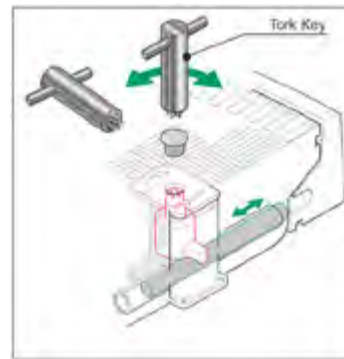

The deadbolt lock system is not only tamper-proof but prevents the cover from dislodging under pressure from within the manhole

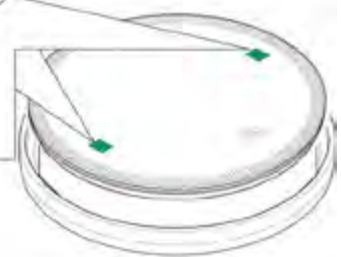

Since installing Fibrelite steam covers, the university has experienced significant reductions in heat transfer from the vault to the manhole surface. Further installations across the campus have now been scheduled as part of a replacement program for numerous 36", 30" & 24" steam covers.



Fibrelite lockable steam covers

## Leading Engineering University Rolls Out Campus-Wide Installation of Fibrelite's Composite Steam Manhole Covers



*Leading Engineering*

Operators of district energy heating systems have become increasingly aware of the dangers posed by hot cast iron manholes. This concern is even more pronounced in campus environments where steam manholes are located throughout the campus and many students tend to wear sandals and “flip flops” in warmer weather.

In 2010, these concerns lead the utilities department of a leading engineering university based in Cambridge, Massachusetts to consider replacing traditional, steel manhole covers with Fibrelite's composite alternative.

After performing testing on their existing steel covers, the system managers concluded that the surface temperature of these manhole covers was dangerously high wherever the underground piping lacked sufficient thermal insulation. Furthermore, during the warmer summer months the heat from the sun would also result in significant temperature increases on the exposed metal covers.

### Fibrelite's Composite Manhole Covers - Cool to Touch!

The thermal gradient properties of Fibrelite's composite steam covers significantly reduce the heat transfer from a steam vault to the surface of the cover. Typically, the surface temperature of the cover will be slightly above the ambient temperature at street level even when subjected to extremely hot temperatures on the underside. Fibrelite's composite access covers have been tested to temperatures up to 400°F while still maintaining their “cool to touch” properties and ability to support vehicular loads.



*Lightweight composite steam covers*

### Fibrelite's Composite Manhole Covers – Proven Results

Since installing Fibrelite's composite manhole covers across the campus, the operators of the university heating system have reported seeing steam covers covered with snow (normally, hot steam covers quickly melt off accumulated snow). Additional surveying has been carried out by flying over the campus with an infra-red camera to locate ‘hot-spots’. The areas where Fibrelite covers had been installed were not visible to the infra-red camera, hence were not radiating any significant amount of heat.



## Leading University Campus Chooses Fibrelite's GRP Composite Steam Manhole Covers

This leading university's engineering and utility project management team first learned about Fibrelite's GRP composite steam manhole covers at an International District Energy Association (IDEA) conference several years ago. In 2009, the engineering team integrated Fibrelite's GRP composite steam manhole covers into a large steam and chilled water expansion project on campus.

**Customer Quote** *"We liked that the covers were light, easy to remove, and were rated for the H20 loading. Our skepticism was around how well the covers in the roadways would hold up to harsh winter snow plowing, and how well they would seal out surface water. To date we have had NO issues with any aspect of these covers. Since our first 6 covers were installed, we have installed 8 others. We are working with Fibrelite to develop plans to retrofit our older vaults in the near future. The Fibrelite covers met an important need on our campus to find a light, durable, temperature, corrosion and abrasion resistant cover that seals out the surface water."*



Fibrelite GRP composite cover, frame and FL7A lifting aid



Pre-cast Fibrelite frames



Fibrelite composite GRP cover installed in frame



View from over the manhole

### How to Eliminate the Hazards - Install Fibrelite Covers!

The hazards of hot manhole covers can be eliminated with Fibrelite's line of GRP composite steam manhole covers. The thermal gradient properties of Fibrelite's GRP composite covers significantly reduce the heat transfer from a steam vault to the surface of the cover. Typically, the surface temperature of the cover will be slightly above the ambient temperature at street level even when subjected to extremely hot temperatures on the underside of the cover.

Fibrelite covers have been third-party tested to handle loads exceeding DOT H20 load ratings even when subjected to temperatures of up to 400°F.

# District Energy Provider, Boston, USA



## Fibrelite Work with District Energy Provider to Replace Aluminum Steam Vault Covers in Busy Pedestrian Area

As part of a refurbishment program to replace/re-lag steam lines in Minneapolis a leading district energy provider has chosen Fibrelite's GRP composite steam trench panels to replace aluminum vault covers in the sidewalk.

Aluminum steam vault covers will conduct nearly all of the heat to the surface of the cover resulting in potentially dangerous conditions.



Previously installed aluminum covers - known for conducting heat to the surface

District energy networks provide customers located within a central city district with heating and cooling services. Steam lines are used to provide heat to apartments, retail stores and office buildings and can give off excess heat and steam thereby creating hot conditions in the steam vault above the steam line. In an effort to reduce heat transfer aluminum and other metal covers are often insulated on the underside



Degraded thermal insulation beneath the old aluminum vault covers

### Lightweight for Easy and Safe Manual Removal, Without Compromising on Strength

Fibrelite's composite GRP trench access covers are proven to be ergonomically safe for men and women to remove and replace and are perfect for access to steam vaults, electrical ducts and underground pipework.



Six Fibrelite FM45 4' 6" (1.6m) wide anti-slip GRP composite trench panels being installed in the sidewalk

### Fibrelite's GRP Composite Trench Panels - Cool to Touch!

Fibrelite's GRP trench panels exceed DOT H20 and H25 even when subjected to temperatures up to 400°F and are available in different load ratings. The thermal gradient properties of Fibrelite's GRP composite trench panels significantly reduce the heat transfer from a steam vault to the surface of the trench panel. Typically, the surface temperature of the panel will be slightly above the ambient temperature at street level even when subjected to extremely hot temperatures on the underside of the trench panel.



No slips or trips... The Fibrelite tread pattern offers anti-slip qualities equivalent to a high grade road surface.





## SHOPPING CENTRES & RETAIL PARKS

**FIBRELITE** 

**WE'VE GOT YOU COVERED**

# Trinity Shopping Centre, Leeds, UK

Fibrelite Supply Shopping Centre with 90m of Composite Trench Covers



190 Fibrelite trench covers are now installed in the state of the art Trinity Shopping Centre in Leeds. The consulting engineers specified Fibrelite for this project for ease of access to cable ducts that run all over the site. The panels are non-slip for a safe working environment in busy service areas in the centre.



Major new shopping centre

## Final Installation



Non slip surface makes for a safe working environment

## British Made Composite Trench Panels

With the head office in Skipton, North Yorkshire (and also manufacturing facilities in the US and Malaysia) Fibrelite is the world's leading and largest manufacturer of composite manhole, trench and access covers and recognised internationally as an innovator in composite technology.



Ensuring a perfect fit, the panels are checked in the encapsulating frame before delivery

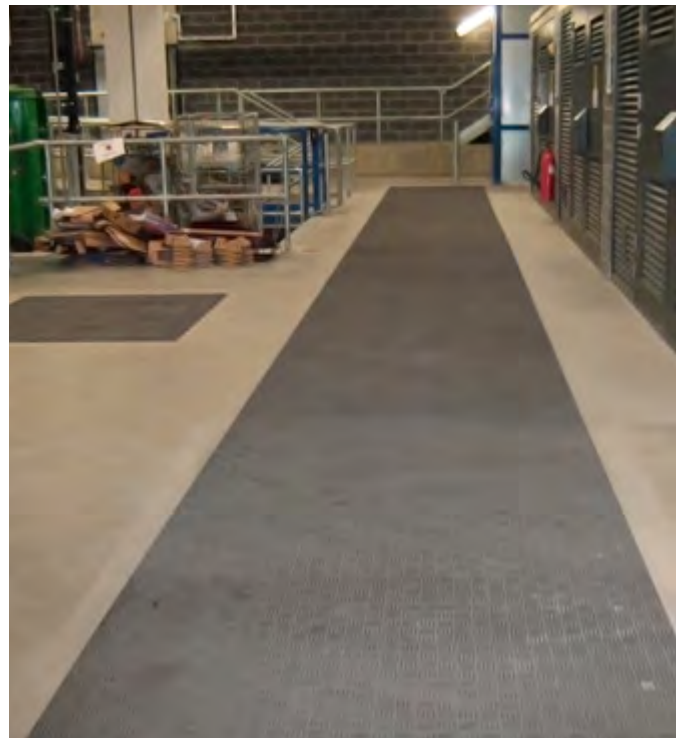

Quick, easy access trench panels



### Benefits Include:

- Lightweight covers enabling easy and safe manual handling
- Wide range of sizes and loadings available
- Anti-slip properties equivalent to a high grade road
- Will not corrode
- Zero re-sale value to the scrap market so will never be stolen

### Fibrelite: The One-Stop-Shop for Trench Covers

Fibrelite's trench panels have a standard width of 450mm, with lengths ranging from 800 to 1600mm. With lengths increasing in 50mm increments (800, 850, 900mm and so on) the customer found that all requirements for different load ratings and sizes could be catered for by Fibrelite. For this project B125, C250 and D400 panels were all used in lengths of 800, 1000, 1400 and 1600mm.



*Fibrelite's trench panels can be used to cover large areas and corners*

### Market Leader for Light-Duty Trench Panels



One of the 8 trench panel installations in the busy city-centre market

### Coloured Trench Covers

A local UK council has specified Fibrelite FM45 trench panels for a busy city-centre market. A series of 8 trenches were previously covered by traditional concrete panels but with constant heavy foot traffic the covers had crumbled and created trip hazards. What's more the concrete was extremely heavy so difficult and unsafe to remove. Metal covers were considered as a replacement but the following benefits meant Fibrelite's GRP composite covers were preferred:

- Lightweight for easy and safe manual removal
- Non-slip properties equivalent to a high grade road
- Will not corrode/rust
- Will not be stolen as there is zero resale value to the scrap market
- Chemically inert
- Extremely strong and durable
- Significantly less CO2 footprint in production and transport

### British Manufacturing at its Best

With many lengths, widths and depths of trench covers available together with the option of adding colour and logos, Fibrelite's trench covers offer an extremely versatile solution. All covers are BS EN 124 load rated, from A15 (1.5 tonne, pedestrian traffic) to E600 (60 tonne). Suitable for many applications ranging from stadiums, water sewage treatment plants, retail, industrial and commercial developments to airports, ports and dockyards.



No trips, slips or falls. Fibrelite's GRP composite covers alongside the old concrete trench panels



Fibrelite's GRP composite access covers: unrivalled strength, robustness and durability





**OPW** 

**DEFINING** | WHAT'S NEXT









# LEARN MORE ABOUT

OPW Products: [opwglobal.com](http://opwglobal.com)

Fibrelite Products: [fibrelite.com](http://fibrelite.com)

KPS Products: [kpsystem.com](http://kpsystem.com)



**OPW**   
a **DOVER** company

DEFINING | WHAT'S NEXT



**OPW** 

**FIBRELITE** 

**KPS**   
PETROL PIPE SYSTEM

+ 44 (0) 1756 799 773

[www.opwglobal.com](http://www.opwglobal.com)