

1.2m square base chamber with a sealed corbel, adjustable skirt and square flat sealed 760mm cover. 1.2m tank flange detail.

For reference purposes only. This drawing is not a specification. Order against product code only. To enable continuous improvement of our products, the designs and specifications are subject to change without notice.

FIBRELITE 
PART OF OPW A DOVER COMPANY

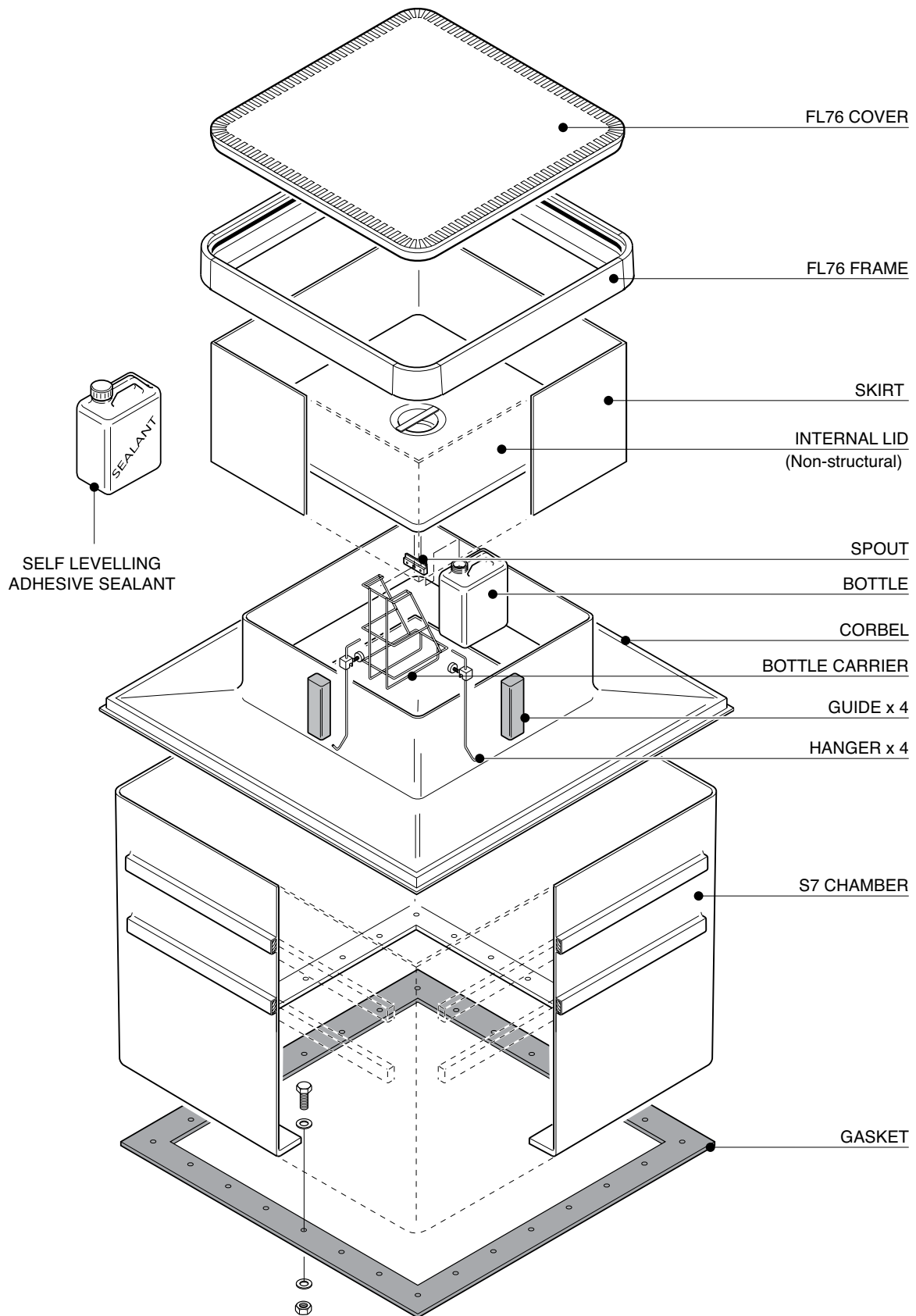

1.2m square base chamber with a sealed corbel, adjustable skirt and square flat sealed 760mm cover. 1.2m tank flange detail.

For reference purposes only. This drawing is not a specification. Order against product code only. To enable continuous improvement of our products, the designs and specifications are subject to change without notice.

FIBRELITE 
PART OF OPW A DOWDER COMPANY

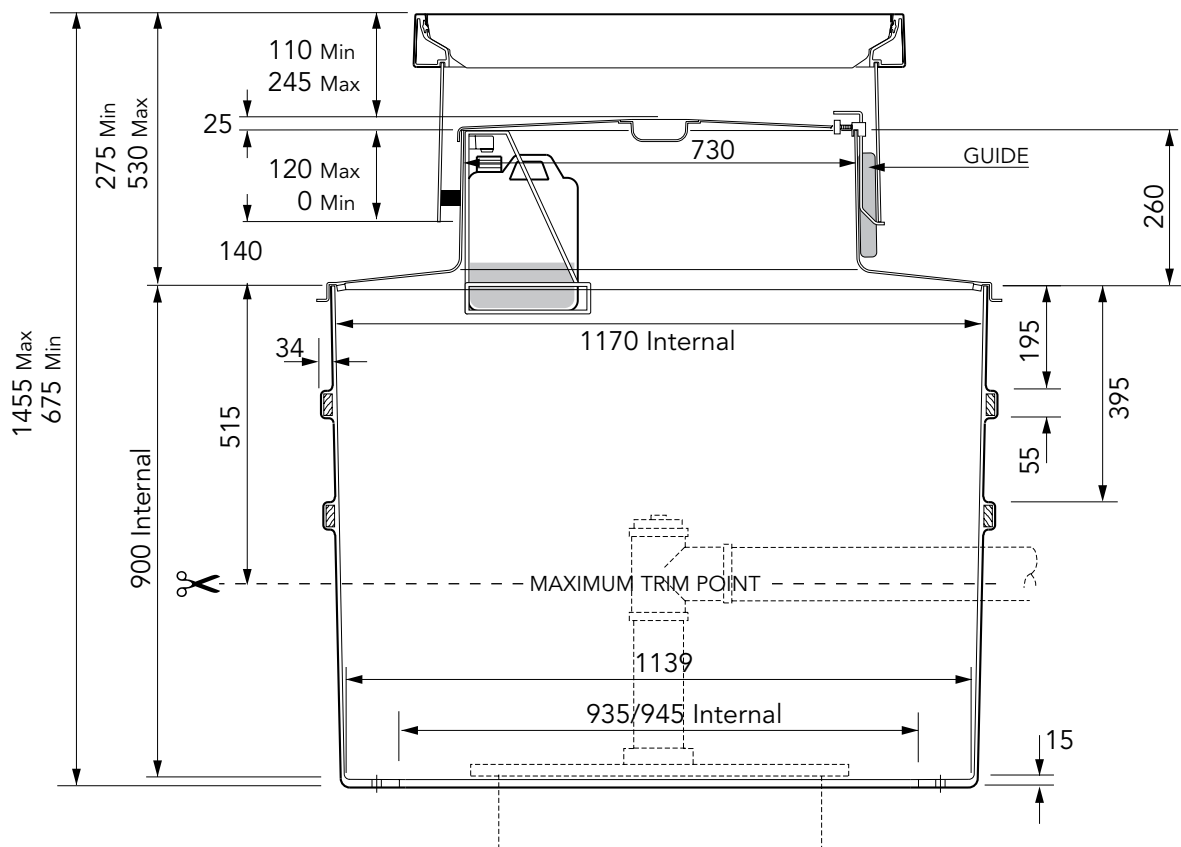
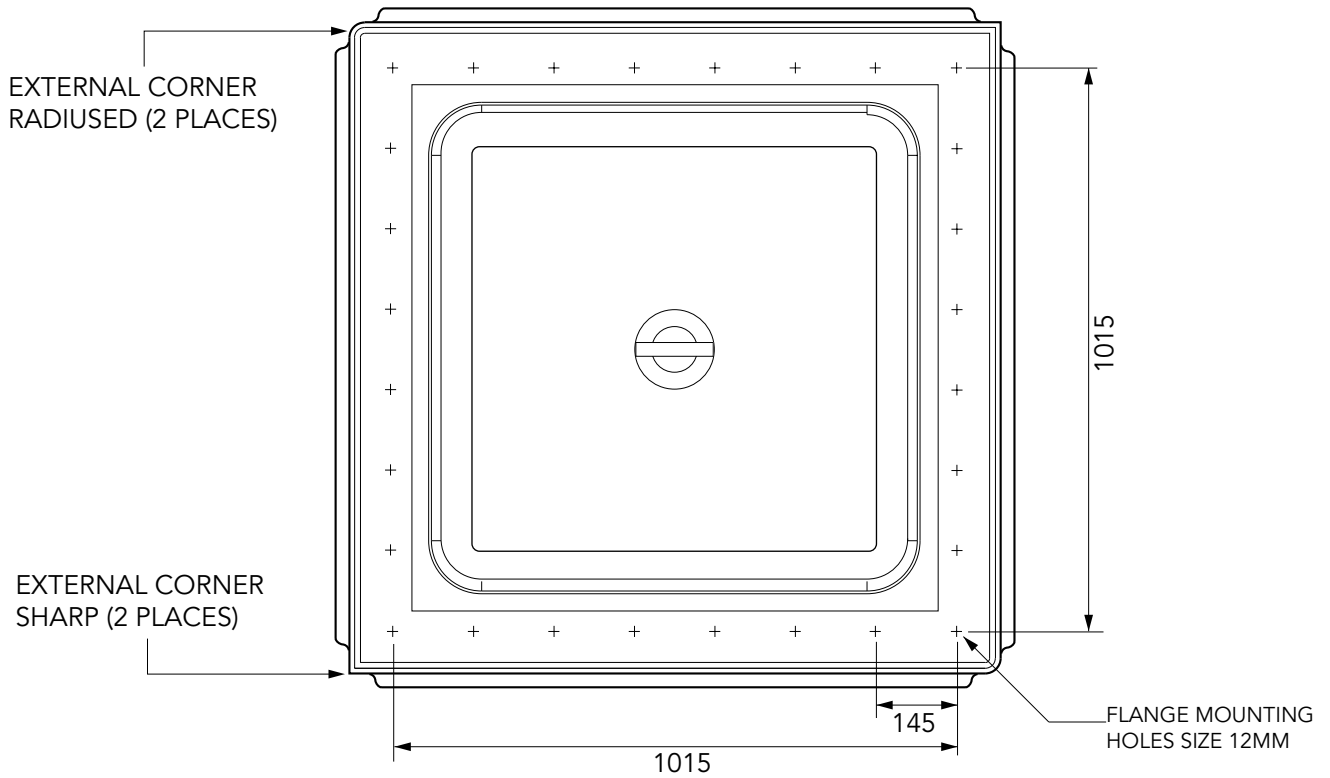

1.2m square base chamber with a sealed corbel, adjustable skirt and square flat sealed 760mm cover. 1.2m tank flange detail.

For reference purposes only. This drawing is not a specification. Order against product code only. To enable continuous improvement of our products, the designs and specifications are subject to change without notice.

FIBRELITE 
PART OF OPW A DOWER COMPANY

VERY IMPORTANT
 OUTER EDGE "A" OF FRAME SET 5 - 10MM
 ABOVE GENERAL FORECOURT AREA WITH
 CONCRETE RAMPED AWAY OVER 300MM.

TYPICAL INSTALLATION

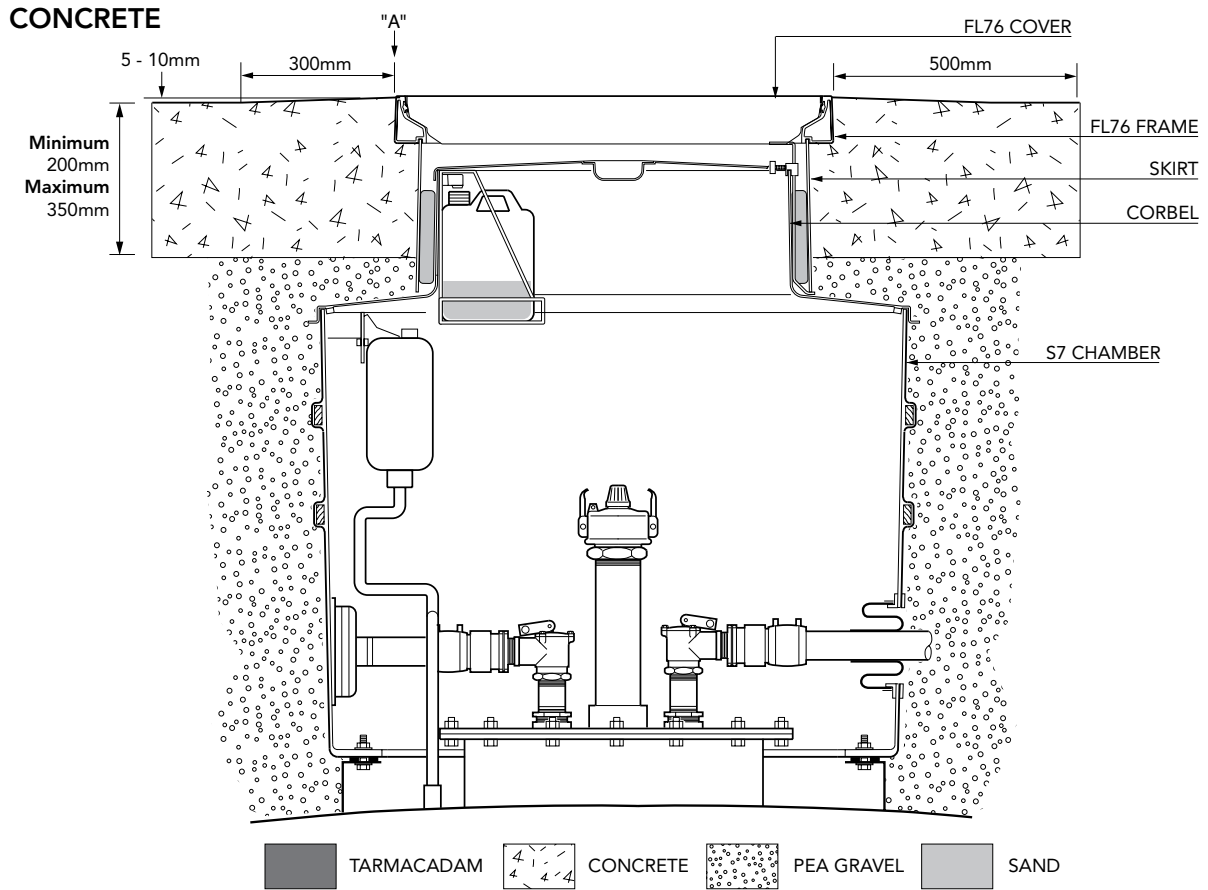

ALTERNATIVE INSTALLATION ADVICE

TARMACADAM

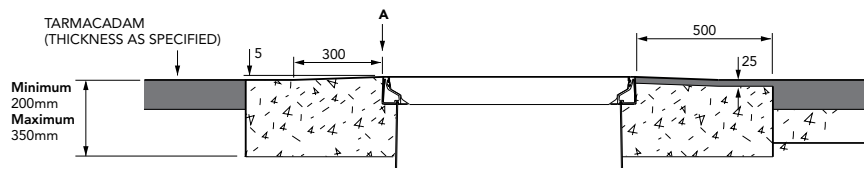

SETTS

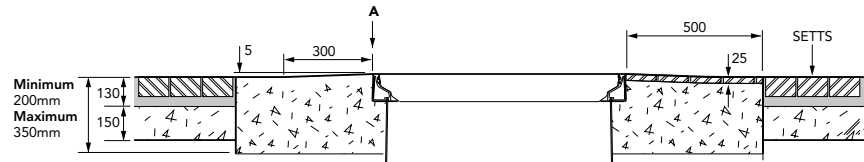

1.2m square base chamber with a sealed corbel, adjustable skirt and square flat sealed 760mm cover. 1.2m tank flange detail.

For reference purposes only. This drawing is not a specification. Order against product code only. To enable continuous improvement of our products, the designs and specifications are subject to change without notice.

